

**CLASS 114-118**

*Sylon Flatwork Ironer*

**ILLUSTATED PARTS MANUAL**



**AMERICAN<sup>®</sup>**

5050 Section Avenue  
Cincinnati, OH 45212-2099

DEC 1946



American Laundry Machinery Inc. 5050 Section Avenue, Cincinnati, Ohio 45212

## Manufacturer's Warranty

The warranty provided by the seller, and which is described herein, covers only new and rebuilt machinery which was manufactured by the seller. Seller makes no warranty on machinery manufactured by others but agrees to pass on to buyer any warranty received by seller on such machinery. Buyer is entitled to the seller's cooperation in obtaining performance on any warranty covering machinery manufactured by others. Used machinery that has not been rebuilt is sold "as is" ("with all faults").

### Warranty and Limitation of Remedy

Under the warranty the seller's obligation is to furnish replacement parts at no charge f.o.b. shipping point, for parts which seller agrees to have been defective in material or workmanship and this is the buyer's exclusive remedy. The buyer agrees to return a defective part (which the seller has agreed to replace) to the seller, freight prepaid and identified to the seller's instructions within 30 days of receipt of the replacement part. The time periods under the warranty are:

Non durable parts are covered for a period of 4 months from the date of shipment of the machinery. Non-durable parts are those items made of flexible materials and expected to wear or deteriorate with time and use. Examples of non-durable parts are gaskets, seals, belts, hoses, and padding.

Other parts are covered as follows:

- New machinery - a period of 13 months from date of shipment of the machinery, or 2000 hours of operation, whichever occurs first.
- Rebuilt machinery - a period of 7 months from date of shipment of the machinery, or 1000 hours of operation, whichever occurs first.

Purchased replacement parts are covered for a period of 90 days from date of shipment.

If machinery is installed by the seller, or if installation is supervised by the seller, the warranty time periods will start with the date of startup instead of the date of shipment -- however, in no event is the warranty time period to exceed eighteen months from date of shipment.

This warranty is contingent upon proper use of the machinery under normal operating conditions, proper installation and maintenance. The seller is not responsible for loose bolts, belts, tubing, wiring, etc.; these items require periodic inspection and maintenance by the buyer. Maintenance instructions must be followed thoroughly to protect the warranty. The warranty becomes void if the equipment has been altered by the user; operated under loads, speeds or electrical current characteristics other than those prescribed by the seller, or damaged by negligence or in an accident.

Seller reserves the right to make changes in design and materials without assuming any obligation to make the same or similar changes to the equipment covered by the terms of this warranty.

This warranty covers only new and rebuilt machinery and repair parts which were manufactured by the seller. Seller makes no warranty on machinery or parts manufactured by others but agrees to pass on to buyer any warranty received by seller on such machinery or parts. Buyer is entitled to seller's cooperation in obtaining performance on any warranty covering machinery or parts manufactured by others.

Used machinery that has not been rebuilt is sold "as is" ("with all faults"). The safety devices on any used equipment are the sole responsibility of the buyer and any product liability claims due to malfunctioning of safety devices are the buyer's responsibility. On such used machinery, the buyer holds the seller harmless from any and all product liability claims.

The buyer assumes responsibility for the maintenance and replacement if necessary of any decals, signs, or other such displays pertaining to safety or operation including but not limited to those which may have been removed or defaced after installation of the machinery.

### Start-Up Labor Services

If machinery is installed by the seller, or if installation is supervised by the seller, start-up labor services are included in the price of the machinery. These start-up labor services include starting up and demonstrating the machinery, performing a reasonable amount of adjustment, and installation of any replacement parts furnished under the machinery warranty. Start-up labor services are provided for a period of 60 days following machinery start up. Start-up labor services are provided on a straight time basis only. The customer assumes responsibility for additional charges incurred for work required to be performed on other than a straight time basis.

### DISCLAIMERS

THE WARRANTIES AND DISCLAIMERS REFERRED TO ABOVE ARE EXCLUSIVE AND IN LIEU OF ALL OTHER WARRANTIES, DISCLAIMERS AND CONDITIONS EXPRESSED OR IMPLIED, INCLUDING THE WARRANTIES, DISCLAIMERS, AND CONDITIONS OF MERCHANTABILITY AND FITNESS FOR PURPOSE AND ALL OTHER CLAIMS. NO ONE HAS AUTHORITY TO MAKE FOR SELLER ANY OTHER REPRESENTATIONS, WARRANTIES OR GUARANTEES. IN NO EVENT SHALL SELLER BE LIABLE FOR DAMAGES, CONSEQUENTIAL OR OTHERWISE, FROM DEFECTS IN THE EQUIPMENT SOLD BY SELLER AND MANUFACTURED BY SELLER OR MANUFACTURED BY OTHERS.

49-002 (Rev. 0180)

## **WARNING**

IT IS THE RESPONSIBILITY OF THE PURCHASER OF THIS MACHINERY TO TRAIN THEIR OPERATING PERSONNEL IN THE PROPER MANNER OF OPERATION.

IT IS FURTHERMORE UNDERSTOOD THAT AMERICAN LAUNDRY MACHINERY ASSUMES NO RESPONSIBILITY FOR INJURY, DISABILITY, OR DEATH RESULTING FROM IMPROPER OPERATION OF, OR REMOVAL FROM, OR BYPASSING THEREOF, OF ANY ELECTRICAL OR MECHANICAL SAFETY DEVICES INCORPORATED IN THE DESIGN AND MANUFACTURING OF THIS MACHINERY.

## **AVERTISSEMENT**

LA RESPONSABILITÉ D'INITIER LE PERSONNEL AU MODE D'EMPLOI APPROPRIÉ INCOMBE A L'ACHETEUR DU MATÉRIEL.

IL EST ÉGALEMENT ENTENDU QU'AMERICAN LAUNDRY MACHINERY N'ASSUME AUCUNE RESPONSABILITÉ EN CAS DE LÉSION, INCAPACITÉ OU DÉCÈS À LA SUITE D'EMPLOI ERRONÉ OU DE L'ENLÈVEMENT OU LE CONTOURNEMENT DE TOUT DISPOSITIF DE PROTECTION ÉLECTRIQUE OU MÉCANIQUE FAISANT PARTIE DE LA CONCEPTION ET DE LA FABRICATION DE CETTE MACHINE.

## **ADVERTENCIA**

EL COMPRADOR ÉSTA RESPONSABLE DE LA ENSEÑANZA AL PERSONAL DEL MODO DE EMPLEO ADECUADO DE ESTA MAQUINARIA.

SE ENTIENDE ADEMÁS QUE AMERICAN LAUNDRY MACHINERY NO ASUMA NINGUNA RESPONSABILIDAD EN CASO DE LESION, INCAPACIDAD, O FALLECIMIENTO A CONSECUENCIA DEL EMPLEO ERRÓNEO O DE LA ELIMINACIÓN O CIRCUNVALACIÓN, DE TODO DISPOSITIVO DE SEGURIDAD ELÉCTRICO O MECÁNICO INCORPORADO EN EL DISEÑO Y LA FABRICACIÓN DE ESTA MAQUINA.

118- 6 ROLL S1 ON FLAT WORK IRONER  
REPAIR PARTS DRAWING INDEX AND MACHINE RECORD

DRAWING NO.	TITLE	FIRST USED ON MACHINE NO. STOCKLISTS	LAST USED ON MACHINE NO.	SUPERSEDED BY
118 RP 1	R.H. OUTSIDE ELEVATION	118M- 118-R82, R75, R76, R77	118M-	
118 RP 2	L.H. OUTSIDE ELEVATION	118M- 118-R82, R75, R76, R77, 110-R26	118M-	
118 RP 3	SECTIONAL ELEVATION OF INSIDE OF R.H. FRAME	118M-	118M-	
118 RP 4	SECTIONAL ELEVATION OF INSIDE OF L.H. FRAME	118M- 118-R82, R75, R76, R77	118M-	
118 RP 5	TYPICAL R.H. FRONT END	118M- 118-R82 110-R56	118M-	
118 RP 5A	PARTS LIST			
118 RP 6	TYPICAL L.H. FRONT END	118M- 118-R82 110-R56	118M-	
118 RP 6A	PARTS LIST			
118 RP 7	TYPICAL DELIVERY END R.H.	118M- 118-R82	118M-	
118 RP 7A	PARTS LIST			
118 RP 8	TYPICAL INSIDE SECTION OF FRONT END	118M- 110-R56 118-R75, R76, R77	118M-	
118 RP 9	TYPICAL INSIDE SECTION OF DELIVERY END	118M- 118-R82	118M-	
118 RP 10	SECTION OF CLUTCH AND DRIVE SHEAVE	118M- 118-R82 MOTOR DRIVES 118-R35, R40, R48, R55	118M-	
118 RP 11	ROLL PRES. IND. MECHANISM	118M- 118-R82	118M-	
118 RP 12	END VIEW OF VACUUM MANIFOLD	118M- 110-R26	118M-	
118 RP 13	DELIVERY TABLE	118M- 118-R75, R76, R77	118M-	
118 RP 14	RAISING RIG ASSEM.	118M- 118-R82	118M-	
118 RP 15	TAPE DEVICE	118M- 3116-R511	118M-	
118 RP 16	MISC. PARTS	118M- 118-R82	118M-	
118 RP 17	GUIDE ROLL BOXES	118M- 118-R82	118M-	



ITEM	NAME OF PART	PART NO.
300	PRESSURE SPRING	3118-657
301	SPECIAL SCREW	3116-6021
302	PRESSURE SPRING CAP	3116-121
303	ROLL BOX	110-160
304	L.H.BKT FOR FEED BOARD	3118-1064
305	SPEEDOMETER HOLDER	110-164
306	L.H.FINGER GUARD SUPPORT ASSEM.	3116-0624
307	L.H.CASTING FOR FINGER GUARD	3116-1041
308	COUPLING FOR FINGER GUARD	3116-1043
309	LEVER FOR FINGER GUARD	118-21
310	CLUTCH LEVER ASSEM.	110-022
311	BRACKET	110-147
312	FORK	3118-195
313	LEVER	110-209
314	STUD	3118-6047
315	SPRING	31140-6003
316	LEVER EXTENSION	110-205
317	SHIFTER KNOB	15-25
318	PIN	361-674
319	ASSEM.UPPER L.H.RIBBON FEED BKT.	110-0125
320	L.H.BRACKET	110-1004
321	L.H.SHAKEOUT BAR BKT.	3116-1347
322	COLLAR FOR SPRING	3116-1387
323	SPRING FOR FINGER GUARD	3116-6484
324	L.H.LOWER RIBBON FEED BKT.	110-189
325	ASSEM.L.H.APRON DRIVE ROLL BKT.	118-012
326	L.H.BRACKET	118-103
327	CLUTCH LEVER SHIELD	110-165
328	UPPER BUSHING	3118-1088
329	LOWER BUSHING	3118-1089
330	FEED ROLL SPROCKET 30T-3/4 P.	3118-425
331	DRIVE SPROCKET 19T-3/4 P.	3118-447
332	IDLE SPROCKET 15T-3/4 P.	3118-0419
333	BUSHING	COMM.
334	DRIVE CHAIN 3/4 P-152 LINKS	118-614
335	IDLER STUD	3118-6118
336	APRON ROLL SPROCKET 21T-3/4 P.	118-44
337	BRACKET FOR ROD BRG.	3118-199
338	BEARING	3118-1000
339	L.H.FEED BOARD BKT.	3118-1405
340	CLUTCH SHIFT ROD	3118-6044
341	KNOCKOUT ROD	118-619
342	1ST <sup>3</sup> / <sub>4</sub> P SPROCKET	3118-438

TYPICAL L.H.FRONT END (PARTS LIST)  
468&12 ROLL SYLON F.W.IRONER

THE AMERICAN LAUNDRY MACHINERY CO

114RP 116RP

11826A 1078

SUPERSEDED BY

SUPERSEDED BY

5-16-47

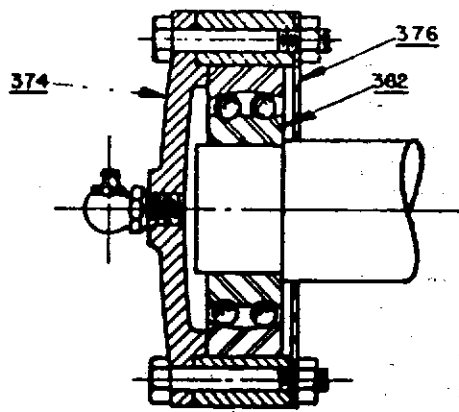

**SECTION OF APRON TENSION  
ROLL BEARINGS**

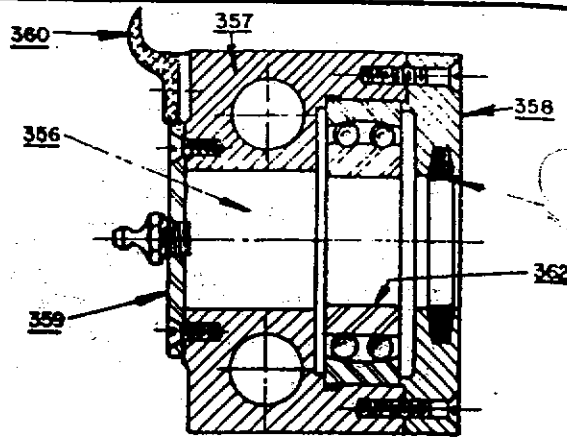

**SECTION OF SPIRAL  
ROLL BEARINGS**

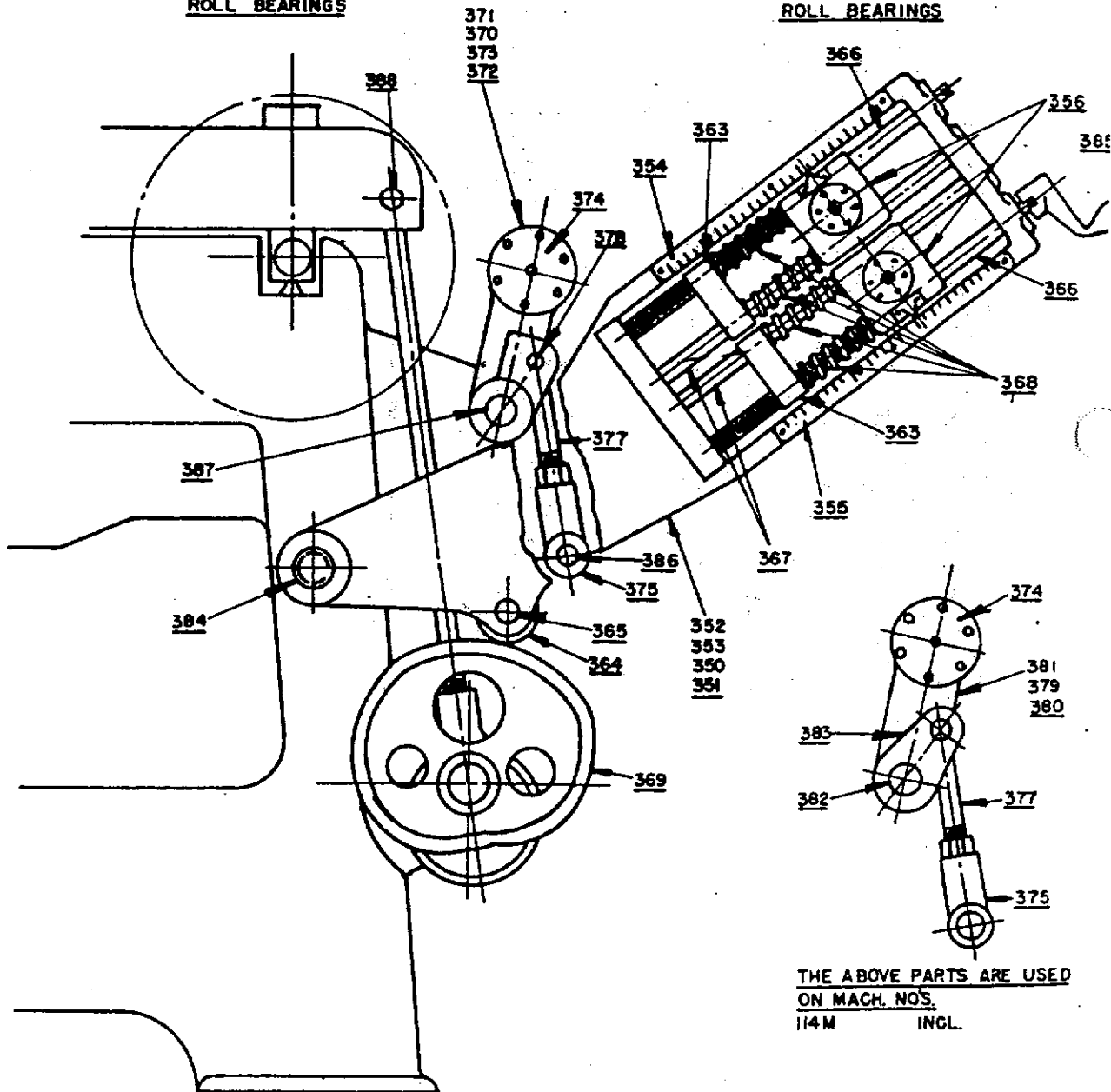

**TYPICAL DELIVERY END (R.H. SIDE ELEV.)  
4,6,8,812 ROLL SYLON F.W. IRONER**

**THE ABOVE PARTS ARE USED  
ON MACH. NOS.  
114 M INCL.**

**THE AMERICAN LAUNDRY MACHINERY**

SUPERSEDES

SUPERSEDED BY

114RP	116RP
118RP	120RP

ITEM	NAME OF PART	PART NO.
350	RH SPIRAL ROLL BRKT ASSEM.	3118-0116
351	LH SPIRAL ROLL BRKT ASSEM.	3118-0118
352	RH SPIRAL ROLL BRKT	3118-1018
353	LH SPIRAL ROLL BRKT	3118-1020
354	RH SCALE	3116-1196
355	LH SCALE	3116-1197
356	ASSEM. SPIRAL ROLL BRG.	3118-0117
357	BRG. HOUSING	3118-1016
358	RETAINER	3118-1016
359	COVER	3118-1017
360	POINTER	3116-1266
361	OIL RETAINER	3118-934
362	1307 SKF BEARING	COMM.
363	SPRING SUPPORT	3118-1019
364	CAM ROLLER	3116-6164
365	PIN	3116-6165
366	SCREW	3118-6075
367	GUIDE ROD	3118-6076
368	SPRING	3118-6077
369	CAM	3118-1068
370	RH APRON TENSION ROLL LEVER ASSEM.	118-014
371	LH APRON TENSION ROLL LEVER ASSEM.	118-015
372	RH LEVER	118-22
373	LH LEVER	118-23
374	COVER	3118-1021
375	CONN. ROD HEAD	3118-1098
376	COVER PLATE	3118-6078
377	CONN. ROD	3118-6239
378	PIN	3118-6240
379	RH APRON TENSION ROLL LEVER ASSEM.	3118-0144
380	LH APRON TENSION ROLL LEVER ASSEM.	3118-0145
381	BEARING LEVER	3118-29
382	PIVOT PIN	3118-6238
383	LEVER	3118-210
384	PIN FOR SPIRAL ROLL BRKT	3116-651
385	APRON TENSION HANDLE	3118-202
386	STUD FOR CONN. ROD	3118-6080
387	PIVOT STUD FOR APRON TENSION ROLL	118-626
388	BOLT IN PRESSURE BAR	3116-8137

TYPICAL DELIVERY END (RH SIDE ELEV) PARTS LIST  
 4,6,8,812 ROLL SYLON FURONER

THE AMERICAN LAUNDRY MACHINERY CO.

114RP	116RP
118RP7A	110RP

SUPERSEDES

SUPERSEDED BY

7-14-47



ITEM	NAME OF PART	PART NO.	ITEM	NAME OF PART	PART NO.
397	APRON FRONT IDLER BRG. ASSEM.	110-012	414	RIBBON SHAFT (100')	3116-6539
398	BRACKET	110-14	415	IDLE ROLL (100')	3140-0802
399	BUSHING	3116-1288	416	IDLE ROLL (110')	3140-0803
400	RIBBON FEED IDLE ROLL BRG	110-0124	417	IDLE ROLL (120')	3140-0804
401	BRACKET	110-1002	418	RIBBON DRIVE ROLL (110')	3116-0881
402	BUSHING	3118-1034	419	RIBBON DRIVE ROLL (100')	3116-0896
403	STEEL FEED BOARD ASSEM. (120')	3116-06167	420	RIBBON DRIVE ROLL (120')	3116-0899
404	BRACKET	118-10	421	R.H. FINGER GUARD BRG.	3116-1182
405	ROD BRACKET	3116-1209	422	SHAKEOUT BAR (100')	3116-948
406	TRUSS ROD (120')	3116-6271	423	SHAKEOUT BAR (110')	3116-949
407	FINGER	3116-6538	424	SHAKEOUT BAR (120')	3116-950
408	RIBBON SHAFT (120')	3116-6541	425	CLOTH COVERING (100')	3116-965
409	STEEL FEED BOARD ASSEM. (110')	3116-06166	426	CLOTH COVERING (110')	3116-966
410	TRUSS ROD (110')	3116-6272	427	CLOTH COVERING (120')	3116-967
411	RIBBON SHAFT (110')	3116-6540	428	FINGER GUARD SHAFT (120')	110-6065
412	STEEL FEED BOARD ASSEM. (100')	3116-06165	429	FINGER GUARD SHAFT (110')	110-6066
413	TRUSS ROD (100')	3116-6273	430	FINGER GUARD SHAFT (100')	110-6067
			431	DOFFER ROLL ASSEM. (120')	3118-0870
			432	DOFFER ROLL ASSEM. (110')	3118-0877
			433	DOFFER ROLL ASSEM. (100')	3118-0887
			434	R.H. DOFFER ROLL BEARING	3118-1119
			435	L.H. DOFFER ROLL BEARING	3118-1120

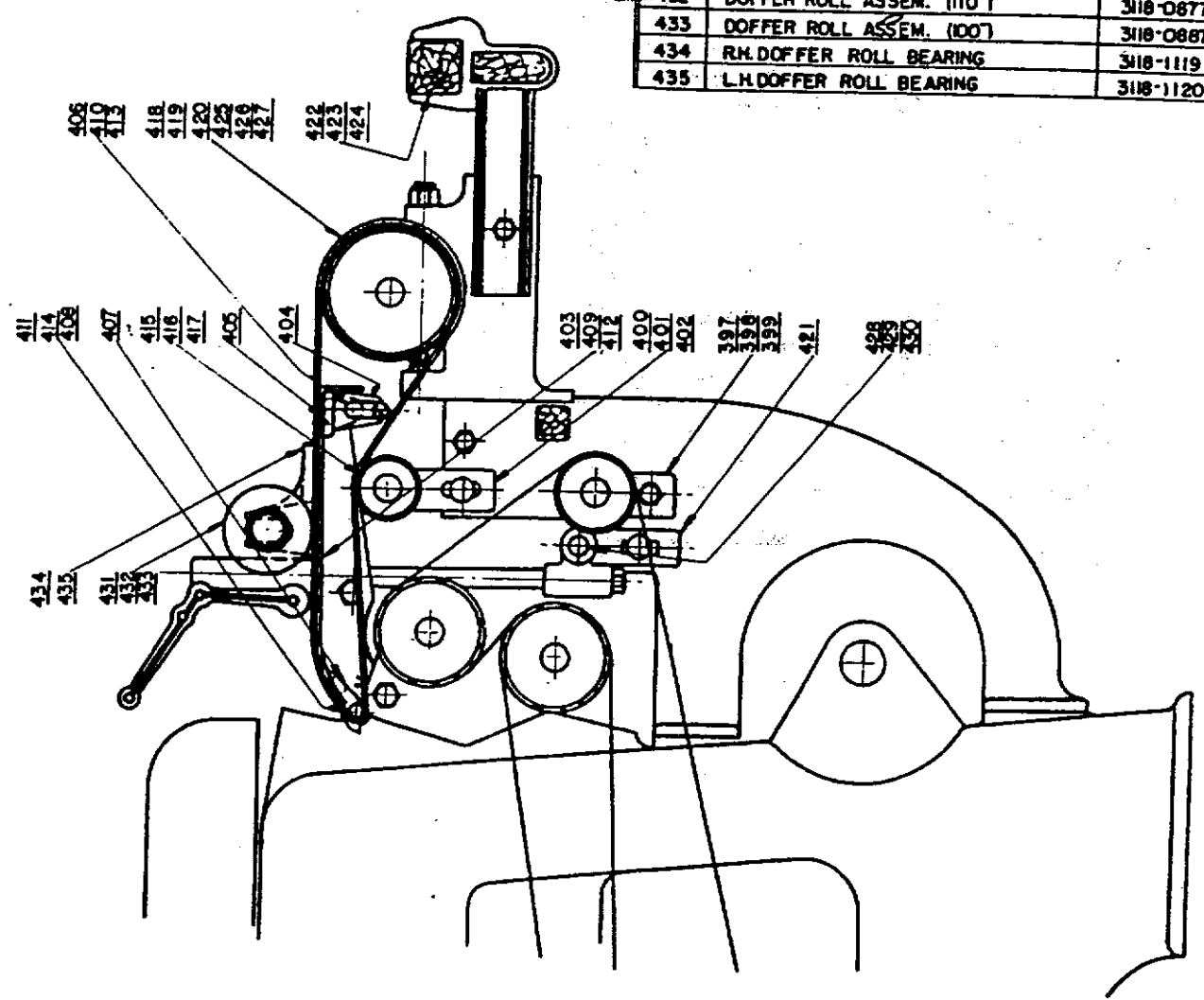

TYPICAL INSIDE SECTION OF FRONT END  
4, 6, 8 & 12 ROLL SYLON EWRONER

THE AMERICAN LAUNDRY MACHINERY CO.

SUPERSEDES

SUPERSEDED BY

7-14-47

114RP	116RP
18RP 6	18RP

ITEM	NAME OF PART	PART NO.
437	WASHER	316-636
438	CHAIN CONN. AT BELL CRANK	316-639
439	CHAIN CONN. AT ROLL	316-640
440	PIN	316-642
441	CHAIN	316-6178
442	NEEDLE FOR APRON GUIDE SPOOL	318-6181
443	APRON GUIDE SPOOL	316-9008

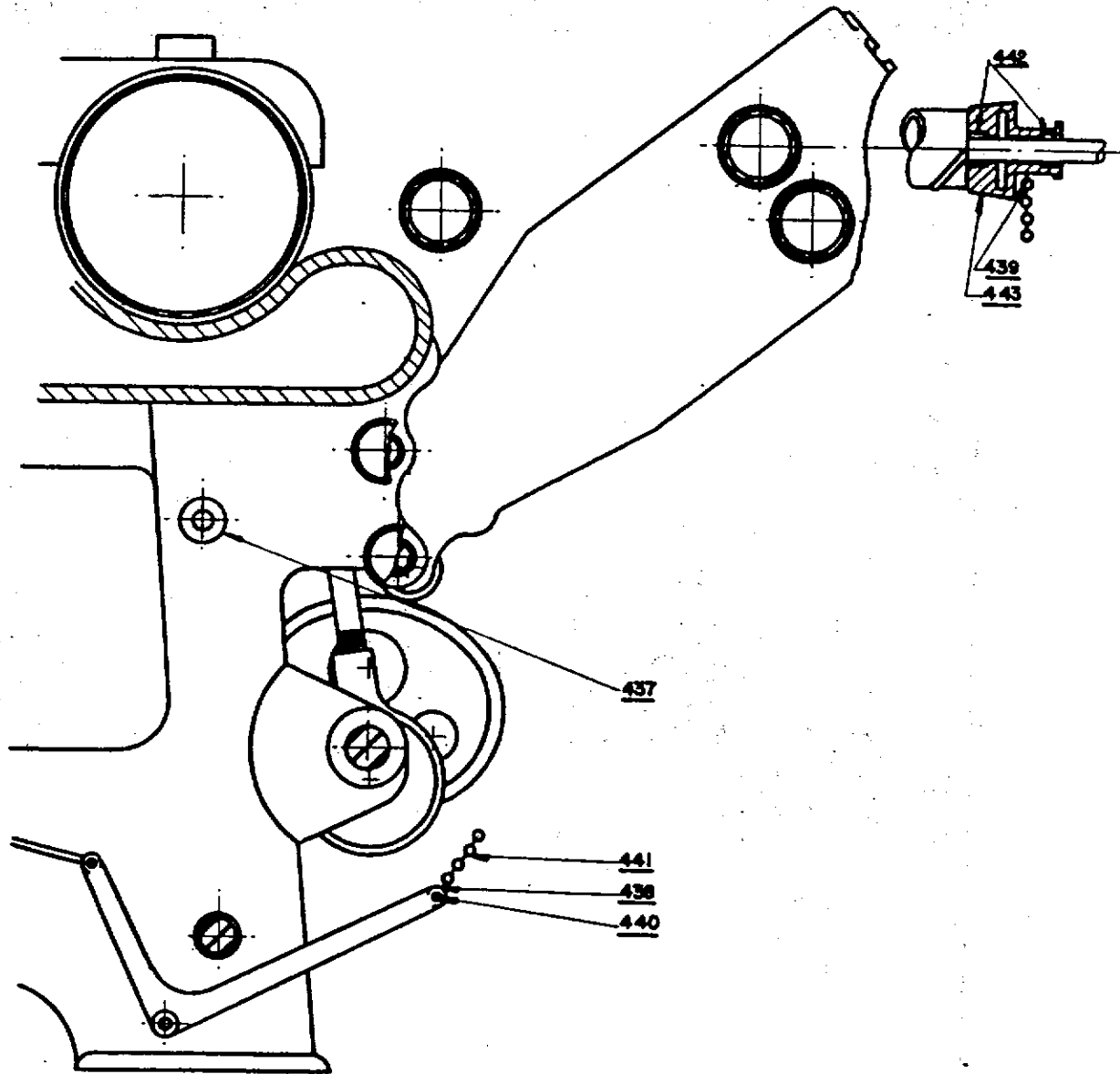

TYPICAL INSIDE SECTION OF DELIVERY END  
4, 6, 8, & 12 ROLL SYLOH FW IRONER

THE AMERICAN LAUNDRY MACHINERY CO.

SUPERSEDES

SUPERSEDED BY

7-15-47

114RP	116RP
116RP 9	117P

ITEM	NAME OF PART	PART NO.	ITEM	NAME OF PART	PART NO.
453	ASSEM. PULLEY BRKT	118-010	469	FORK FOR ROD	3118-23
454	BALL BEARING FOR PULLEY BRKT	3118-0130	470	CONE LEVER	110-26
455	ASSEM. CONE BRKT	3118-0135	471	LEVER FOR CLUTCH	110-27
456	SHEAVE ASSEM. 30° PD.	3118-030	472	THROWOUT LEVER	3118-27
457	SHEAVE ASSEM. 26.75° PD.	3116-034	473	50T. SPEED IND. DRIVE GEAR	3116-4026
458	SHEAVE ASSEM. 30° PD.	3116-036	474	NOTCH COLLAR	110-617
459	CONE BRKT.	110-140	475	SHAFT	110-618
460	DISC HOUSING	3118-186	476	STUD FOR ROLLER	3118-6036
461	COVER	3118-189	477	STUD FOR FORK	3118-6040
462	PLATE FOR CONE BRKT.	3118-190	478	STUD FOR THROWOUT LEVER	3118-6041
463	SLIDING RECE.	3118-192	479	STUD FOR LEVER	3118-6055
464	UNIV. DRIVE HEAD WITHOUT CLAMP	31140-1012	480	COLLAR	3118-6059
465	PULLEY BRKT.	3118-1056	481	ROLLER	3118-848
466	SUPPORT FOR DRIVE SHAFT	3118-1057	482	BOCKFORD FRICTION CLUTCH	COMM. 118
467	FORK FOR FRICTION CLUTCH	3118-1058	483	SPEED INDICATOR PINION BRKT.	110-158
468	BUSHING FOR SHEAVE	3116-1339	484	SPRING FOR THROWOUT LEVER	3118-6046
			485	THRUST COLLER	118-104

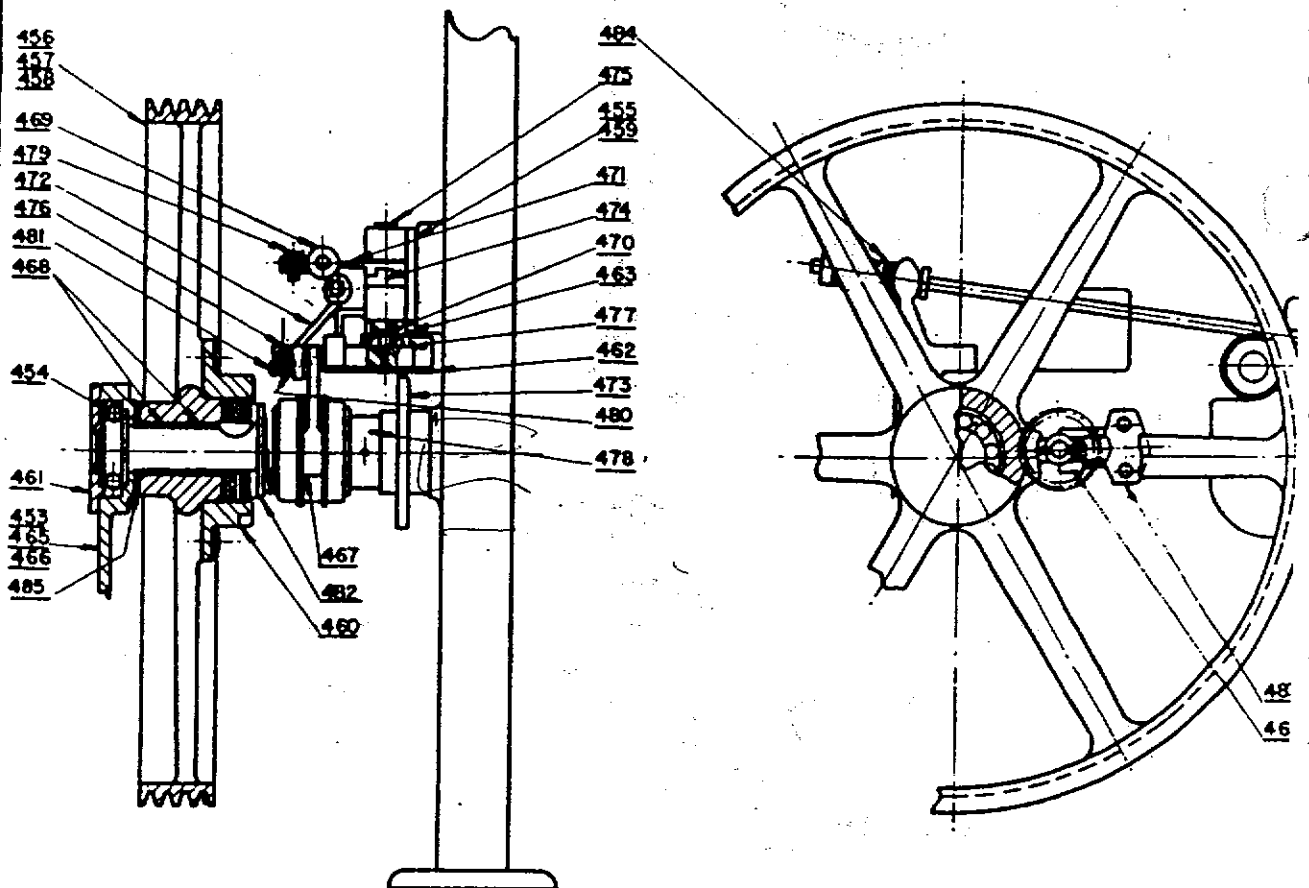

SECTION OF CLUTCH & DRIVE SHEAVE  
4 6 8 & 12 ROLL SYLON F.W. IRONER

THE AMERICAN LAUNDRY MACHINERY CO

SUPERSEDES

SUPERSEDED BY

716-47

114RP	116RP
118RP10	1105P

ITEM	NAME OF PART	PART NO.
493	BRKT FOR BEVEL GEAR SHAFT ASSEM.	110-0128
494	ROLL PRESSURE INDICATOR ASSEM.	110-0129
495	BUSHING FOR BRKT	102-113
496	CASE	110-182
497	SNAP RING	110-185
498	DIAL	110-1010
499	BEARING BRKT FOR BEVEL GEARS	110-1014
500	LOWER LEVER	110-218
501	RETAINING WASHER	3913-62
502	PIN FOR CONN. ROD	3121-645
503	NUT FOR CAM (P.R.R.)	110-648
504	SHAFT	110-6007
505	POINTER	110-6010
506	BEVEL GEAR SHAFT	110-6079
507	STUD FOR BEVEL PINION	110-6080
508	STL. BEVEL PINION 16T. 16P.	COMM.
509	STL. BEVEL PINION 32T. 16P.	COMM.
510	GLASS	110-96

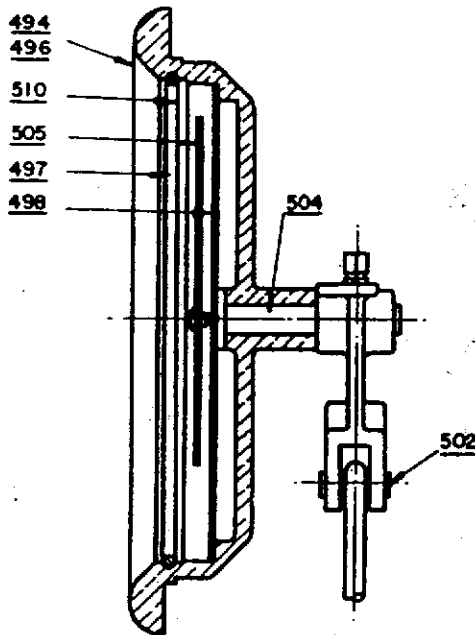

ROLL PRESSURE INDICATOR ASSEM.

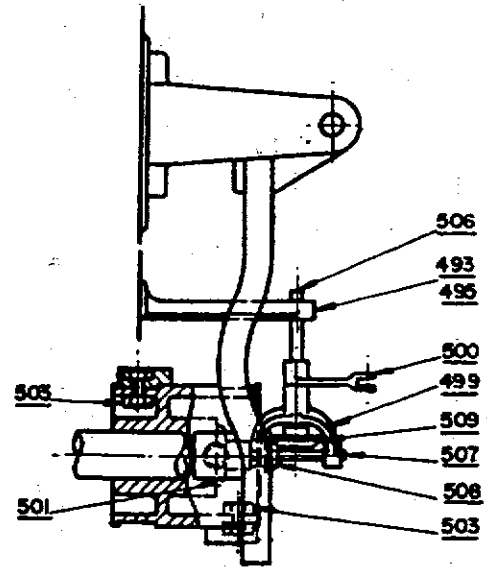

KNOCKOFF CAM HOLDER ASSEM.

ROLL PRESSURE INDICATOR MECHANISM  
4, 6, 8, & 12 ROLL SYLON FEEDER

THE AMERICAN LAUNDRY MACHINERY CO.

114 RP	116 RP
118 RP II	110 RP

SUPERSEDES

SUPERSEDED BY

7-7-47

ITEM	NAME OF PART	PART NO.	ITEM	NAME OF PART NO.	PART NO.
520	EXHAUST FAN HOUSING ASSEM.	3116-01053	535	SWING JOINT BODY	3116-730
521	VACUUM MANFOLD	110-0703	536	SWING JOINT COVER	3116-731
522	ASSEM SWING JOINT	3116-0726	537	PACKING FOR SWING JOINT	3116-982
523	SUPPORT BRKT	3116-1363	538	PACKING FOR SLIP JOINT	31140-941
524	MOTOR BRKT.	3116-1364	539	GARLOCK PACKING NO.117	COMM.
525	WRENCH FOR SWING JOINT	3116-259	540	R/EXHAUST FAN HOUSING ASSEM.	3116-0105
526	IMPELLER	3116-319	541	R/LHOUSING	3116-5060
527	APRON ROLL SPROCKET 21T. 3/4 P.	118-44	542	COVER	3116-6390
528	EXHAUSTER HOUSING	3116-5034	543	GASKET	3116-983
529	ANGLE IRON HOLDING OIL PIPES	3116-6283			
530	SWING JOINT LOCK	3116-6422			
531	SLIP JOINT LOWER PIPE	110-73			
532	SPLIT COLLAR	31140-73			
533	SLIP JOINT UPPER PIPE	31140-703			
534	SLIP JOINT LOCKING NUT	31140-705			

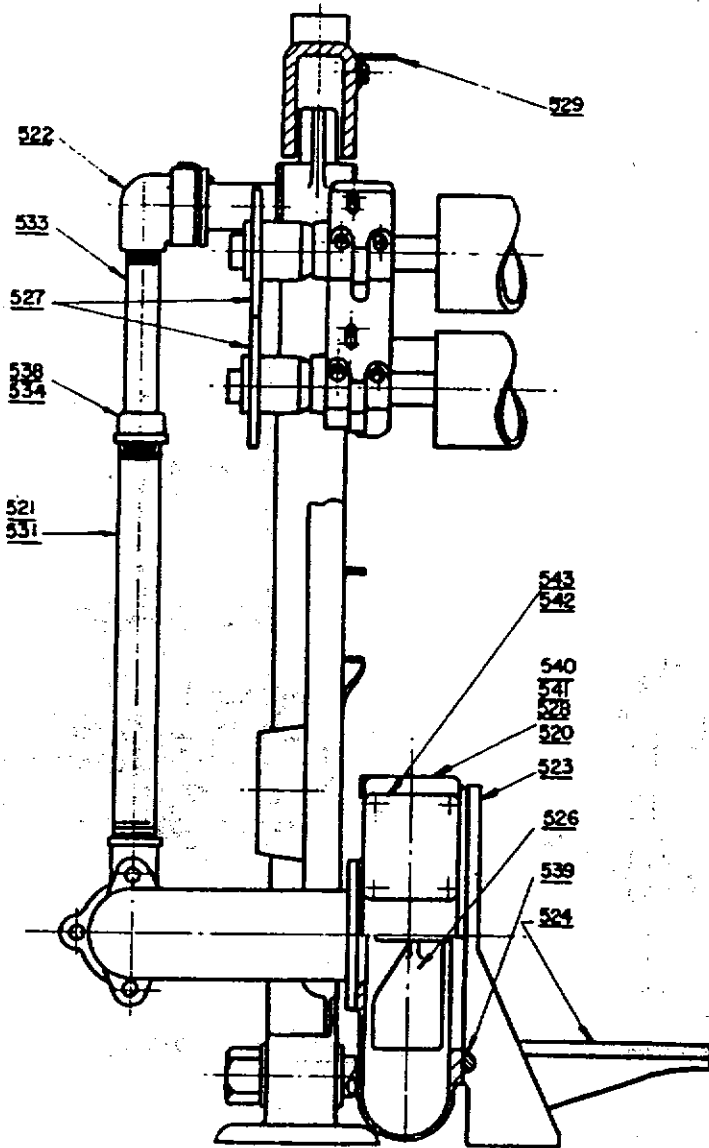

END VIEW SHOWING VACUUM EXHAUSTER SYSTEM

END VIEW OF VACUUM EXHAUSTER  
4.6.8 & 12 ROLL SYLON FWIRONER

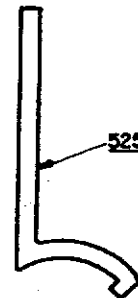

SWING JOINT WRENCH

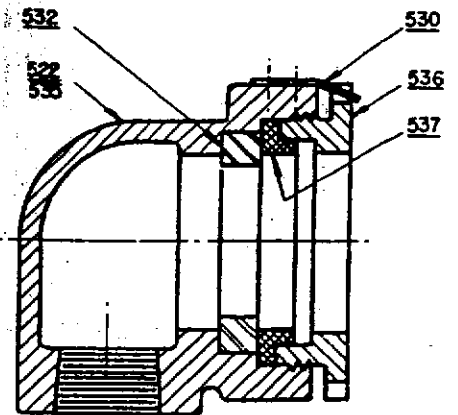

SECTION OF SWING JOINT FOR VACUUM EXHAUST

THE AMERICAN LAUNDRY MACHINERY CO.

SUPERSEDES

SUPERSEDED BY

7-16-47

114RP	116RP
118RP 12	110FP

ITEM	NAME OF PART	PART NO.
550	ADJUSTABLE TABLE LEG ASSEM.	110-0527
551	DELIVERY TABLE (110")	116-090
552	DELIVERY TABLE (100")	116-091
553	DELIVERY TABLE (120")	318-0916
554	BRACKET	3116-1190
555	CAST IRON WASHER	3116-1231
556	FOOT FOR ADJ. LEG	116-513
557	TOP FOR ADJ. LEG	116-514
558	HINGE PIN	3116-6302
559	TIE PIPE (120")	3118-707

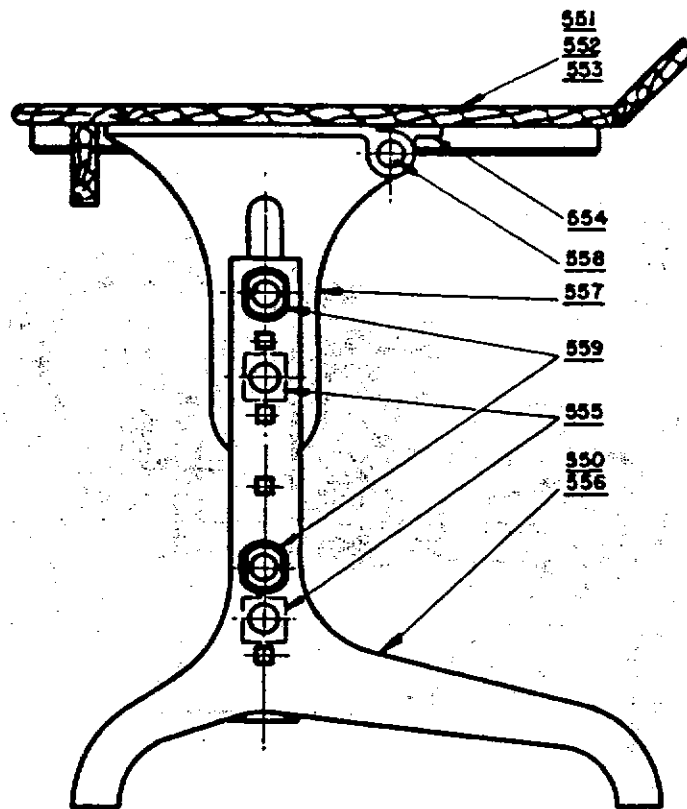

DELIVERY TABLE  
4, 6, 8, 12' ROLL SYLON FWIRNER

THE AMERICAN LAUNDRY MACHINERY CO.

114RP	116RP
118RP 13	116RP

SUPERSEDES

SUPERSEDED BY

7-21-47

ITEM	NAME OF PART	PART NO
569	RAISING RIG ASSEM.	110-0132
570	SPUR GEAR ASSEM. INTER. SHAFT	110-0405
571	MAIN BRACKET	110-1007
573	THRUST BRG. FOR PINION	3118-1069
574	SHIFTER SPOOL	3116-1091
575	HAND WHEEL	3118-303
576	34T 5P SPUR GEAR	110-48
577	BEVEL GEAR	110-408
578	14T 5P SPUR GEAR (MEEH.)	3118-426
579	32T 5P SPUR GEAR (MEEH.)	3118-429
580	BEVEL PINION	110-431
581	14T 5P SPUR GEAR (STL.)	110-434
582	14T 5P SPUR GEAR (STL.)	110-435
583	20T 5P SPUR GEAR (STL.)	110-436
584	BEVEL GEAR COVER	3116-680
585	CLUTCH SHAFT	110-620
586	CLUTCH KEY	110-644
587	HAND WHEEL SHAFT	110-6072
588	GEAR SHAFT	110-6073
589	SPRING FOR SPACER	110-6075
590	SHIFTER ROD	110-6078
591	SPACER FOR CLUTCH GEAR	3116-6159
592	PIN	3116-6182
593	GUARD FOR RAISE RIG	118-0511

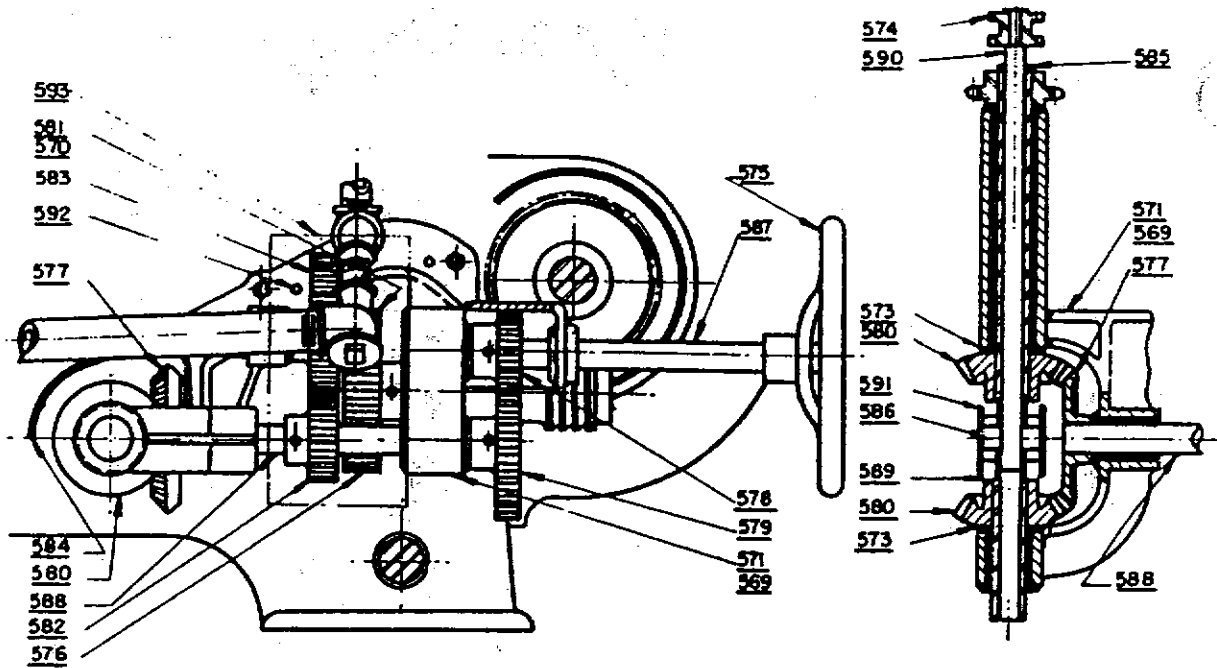

RAISING RIG ASSEMBLY  
6, 8, & 12 ROLL SYLON F.W. IRONERS

THE AMERICAN LAUNDRY MACHINERY CO.

ITEM	NAME OF PART	PART NO.
602	ASSEM. SPOOL ARM	3116-01088
603	ASSEM. SPOOL ROD (120')	3116-06125
604	ASSEM. SPOOL ROD (110')	3116-0626
605	ASSEM. SPOOL ROD (100')	3116-0627
606	REAR RIBBON SPOOL BRKT.	3118-1084
607	SPOOL ARM	3116-1356
608	R.H. BRKT FOR SPOOL	3116-1358
609	L.H. BRKT FOR SPOOL	3116-1359
610	SPOOL ARM HOLDER	3116-1431
611	PIN FOR SPRING	1802-605
612	SPRING	1802-606
613	STUD	3116-6419
614	SPOOL ROD (120')	3116-6421
615	SPOOL ROD (110')	3116-6423
616	SPOOL ROD (100')	3116-6425
617	SPOOL ARM SUPPORT (100)	3116-6584
618	SPOOL ARM SUPPORT (110)	3116-6585
619	SPOOL ARM SUPPORT (120)	3116-6586
620	SPOOL STOP	3116-920
621	WOOD SPOOL	3116-989
622	TAPE	3116-986

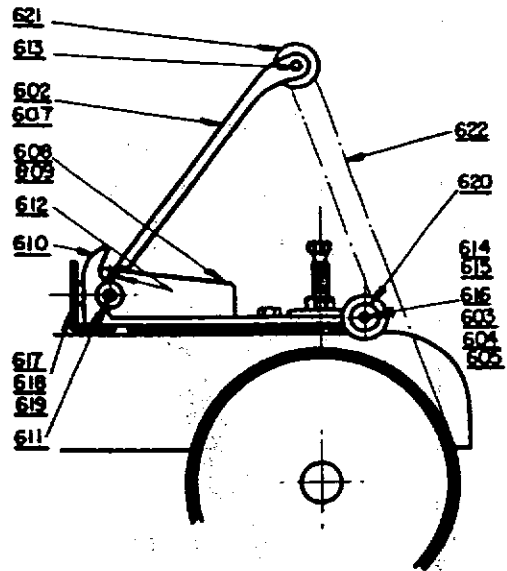
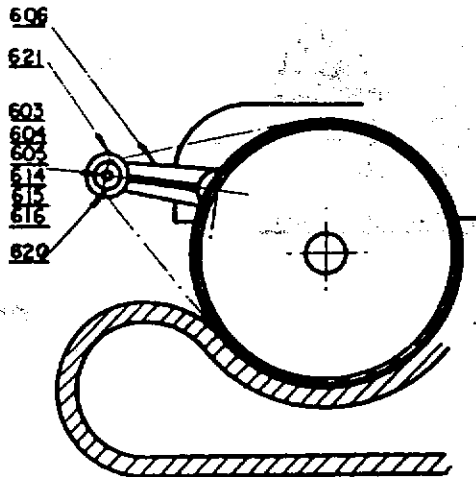

TAPE DEVICE  
4, 6, 8, & 12 ROLL SILON EW. IRONER

THE AMERICAN LAUNDRY MACHINERY

114RP	116RP
11E RP 15	



ITEM	NAME OF PART	PART NO.
631	GUIDE BLOCK FOR CHESTS	3116-1277
632	CRANK FOR HAND DRIVE	3116-242
633	PIN FOR GUIDE BLOCK	30-609
634	NO.7 EYEBOLT FOR GUARDS	3619-6035

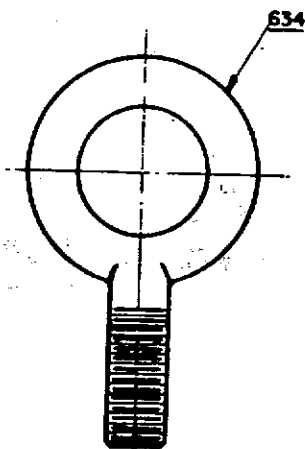

EYEBOLT FOR GUARDS

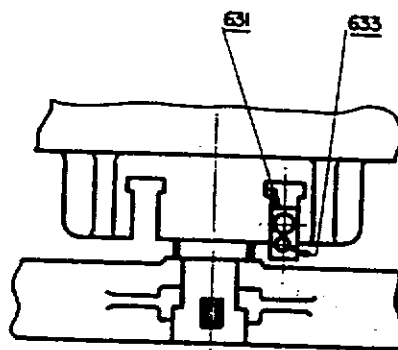

METHOD OF MOUNTING CHESTS

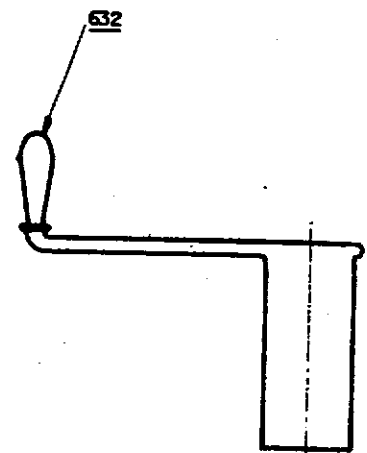

HAND CRANK

MISCELLANEOUS PARTS  
4, 6, 8 & 12 ROLL SYLON EW. IRONER

THE AMERICAN LAUNDRY MACHINERY CO.

SUPERSEDES

SUPERSEDED BY

7-24-47

114RP	116RP
118RP 16	110RP

ITEM	NAME OF PART	PART NO.
644	ADJ. BOX APRON GUIDE ASSEM.	3116-01023
645	ASSEM. BOX	3116-01024
646	AUTO. ADJ. BOX ASSEM.	3116-01025
647	APRON BOX ASSEM.	3116-01026
648	APRON GUIDE ADJUSTER	3116-1014
649	GUIDE BOX	3116-1204
650	GUIDE BOX	3116-1205
651	BAR	3116-1206
652	GUIDE SLIDE	3116-1207
653	ROLLERS	3116-633
654	WASHER	3116-636
655	SHAFT	3116-6070
656	PLATE	3116-6364
657	PINS	3116-6365
658	STUD	3116-6367
659	HYATT ROLLER BEARING P 95424	COMM.

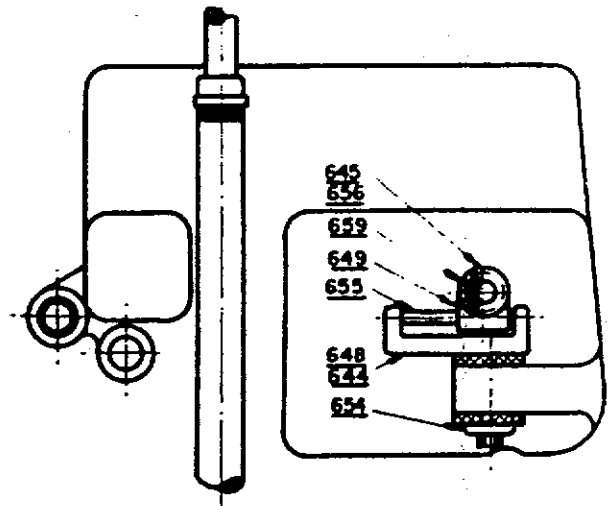
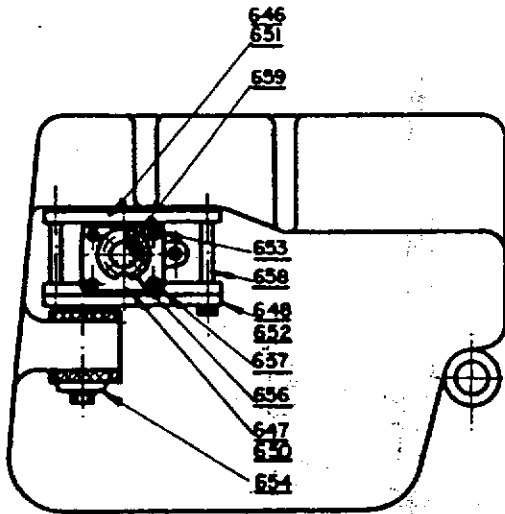

GUIDE ROLL BOX ASSEMBLIES  
 4, 6, 8, 812 ROLL SYLON FW IRONERS

THE AMERICAN LAUNDRY MACHINERY CO.

114RP	116RP
118RP17	110RP

SUPERSEDES

SUPERSEDED BY

724-67

ITEM	NAME OF PART	PART NO
669	SHAKEOUT STAND ASSEM.	3112-052
670	FOOT	3113-107
671	TIE ROD	3112-618
672	PIN IN FOOT	3112-6017
673	UPPER HORIZONTAL PIPE	3116-72
674	VERTICAL PIPE	3116-73
675	LOWER HORIZONTAL PIPE	3116-74

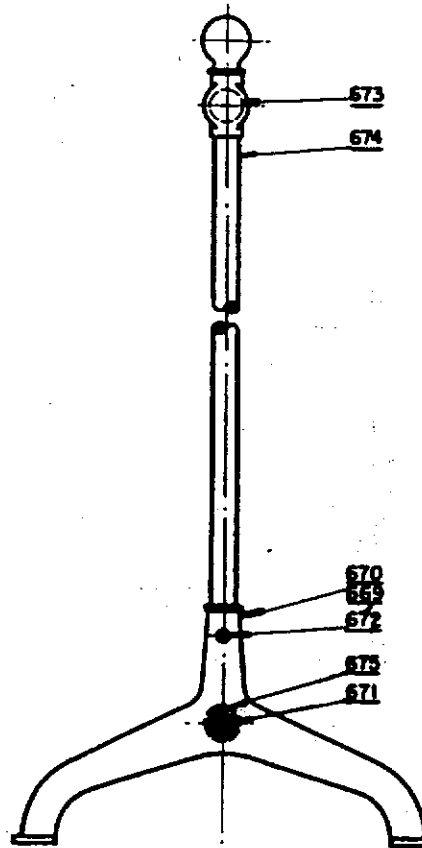

SPECIAL  
SHAKEOUT STAND  
4, 6, 8, & 12 ROLL SYLON EWIRONERS

THE AMERICAN LAUNDRY MACHINERY

114RP	116RP
118RP 18	110RP

SUPPESSEDES

SUPERSEDED BY

7-25-47

ITEM	NAME OF PART	PART NO
685	ASSEM THERMOMETER WELL	316-0707
686	THERMOMETER SUPPORT	316-6293
687	THERMOMETER WELL	316-706

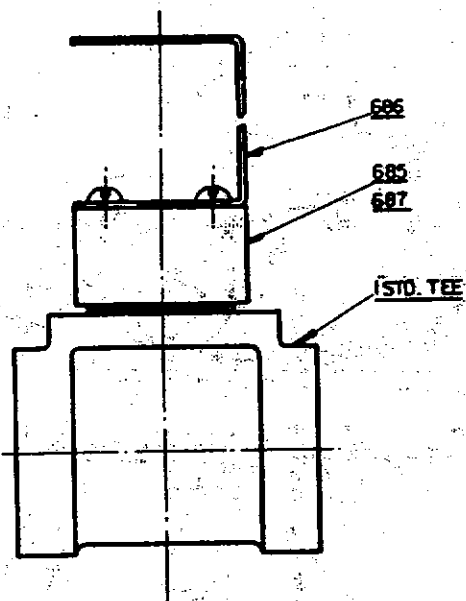

SPECIAL

THERMOMETER WELL  
4, 6, 8, & 12 ROLL SYLON FW. IRONERS

THE AMERICAN LAUNDRY MACHINERY

114 RP	116 RP
118 RP 19	110 RP

SUPERSEDES

SUPERSEDED BY

7-27-57

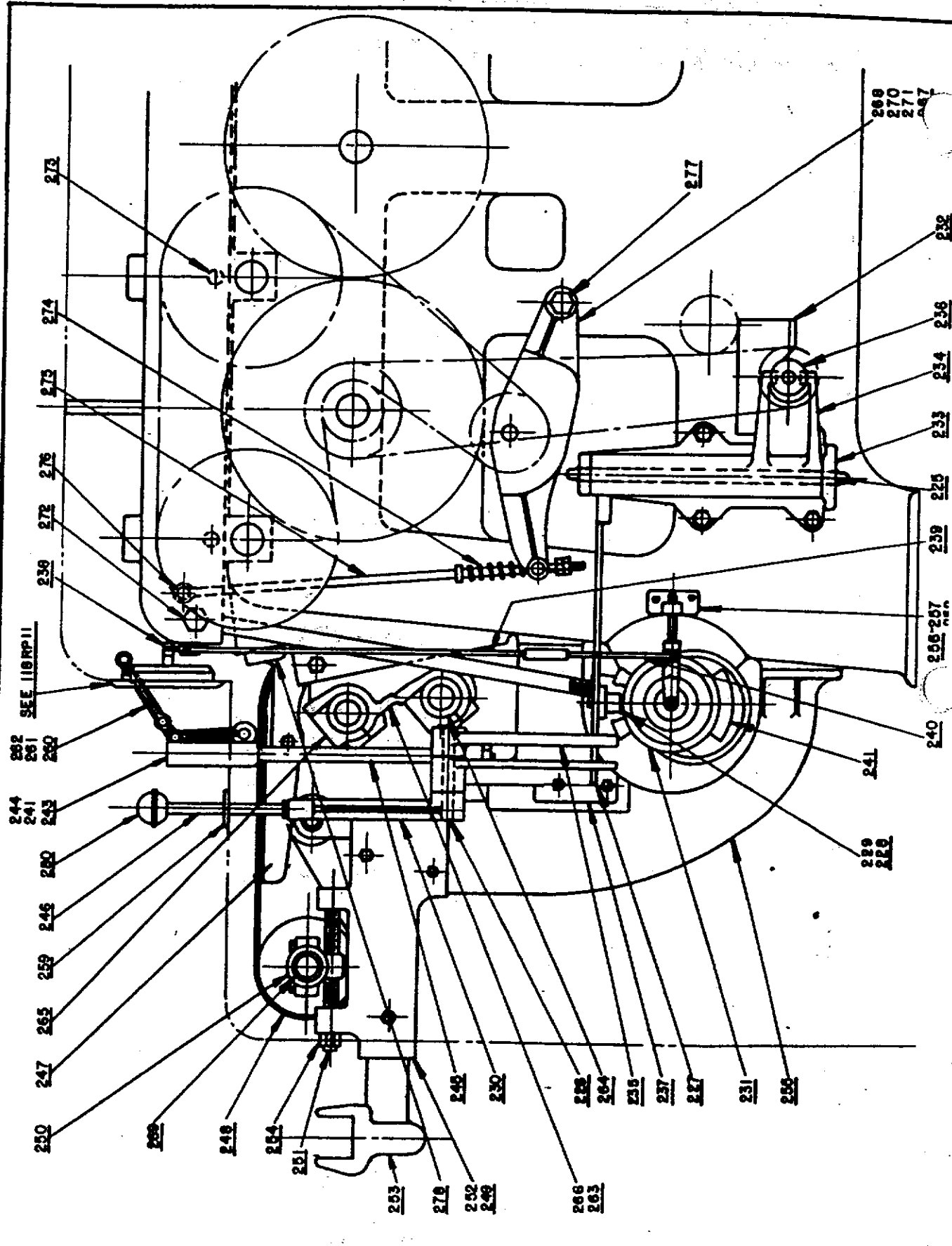

TYPICAL R.H. FRONT END (SIDE ELEVATION)  
 4.6, 8 & 12 ROLL SYLON F.W. IRONERS

THE AMERICAN LAUNDRY MACHINERY CO

114 RP	116 RP
--------	--------

ITEM	NAME OF PART	PART NO.
225	CLUTCH SHIFTER SHAFT	110-6054
226	SHIFT LEVER PIN	110-6053
227	ASSEM. CLUTCH LEVER	110-0617
228	PIN	3116-6531
229	ROLLER	3116-6532
230	SHIFT LEVER	110-215
231	KNOCKOUT CAM HOLDER	110-1011
232	SUPPORT PLATE	110-1008
233	SUPPORT BRACKET	110-1001
234	CLUTCH SHIFTER	110-217
235	LOWER SHIFT LEVER	110-216
236	SHIFTER SPOOL	3116-1091
237	SHIFTER LEVER BRACKET	110-193
238	LEVER FOR PRESSURE INDICATOR	110-219
239	UPPER EYE ROD	110-6081
240	LOWER EYE ROD	110-6082
241	KNOCK OFF CAM	110-155
242	R.H. FINGER GUARD SUPPORT ASSEM.	3116-0623
243	SUPPORT	3116-1042
244	COUPLING	3116-1043
246	ROD	3116-6096
248	SHIFT LEVER EXTENSION	110-214
247	R.H. FEED BOARD BKT.	3116-1406
248	RIBBON	3116-947
249	ASSEM. UPPER R.H. RIBBON FEED BKT.	110-0125
250	BEARING ASSEM.	3116-01048
251	TAKE-UP SCREW	3116-6418
252	R.H. BRACKET	110-1003
253	R.H. SHAKEOUT BAR BKT.	3116-1348
254	HEX COLLAR	3116-6527
255	LOWER R.H. RIBBON FEED BKT.	110-190
256	BKT FOR BEVEL GEAR SHAFT	110-0128
257	BKT.	110-1013
258	BUSHING	102-113
259	RAISE RIG LEVER SHIELD	110-1012
260	ASSEM. FINGER GUARD 120"	3116-06108
261	ASSEM. FINGER GUARD 110"	3116-06107
262	ASSEM. FINGER GUARD 100"	3116-06106
263	ASSEM. R.H. BRG. BRACKET	118-011
264	BUSHING	3118-1088
265	CAP	3118-1090
266	BRACKET	118-102
267	ASSEM. CHAIN IDLER LEVER	118-020
268	LEVER	118-20
269	BUSHING	3116-1329
270	SWIVEL PIN	118-615
271	SPROCKET AXLE	110-636
272	PIN FOR PENDULUM BOLT	31140-65
273	PIN FOR ROLL BOX	3116-652
274	SPRING	285-606
275	CONNECTING ROD	118-616
276	PIN	118-620
277	STUD	110-635
278	R.H. BKT. FOR STEEL FEED BOARD	3116-1269
280	SHIFTER KNOB	15-25

-128-900

TYPICAL R.H. FRONT END (PARTS LIST)  
 46,8A12 ROLL SYLON F.W. IRONERS

THE AMERICAN LAUNDRY MACHINERY CO

114RP	116RP
118RP.5A	110 RP.

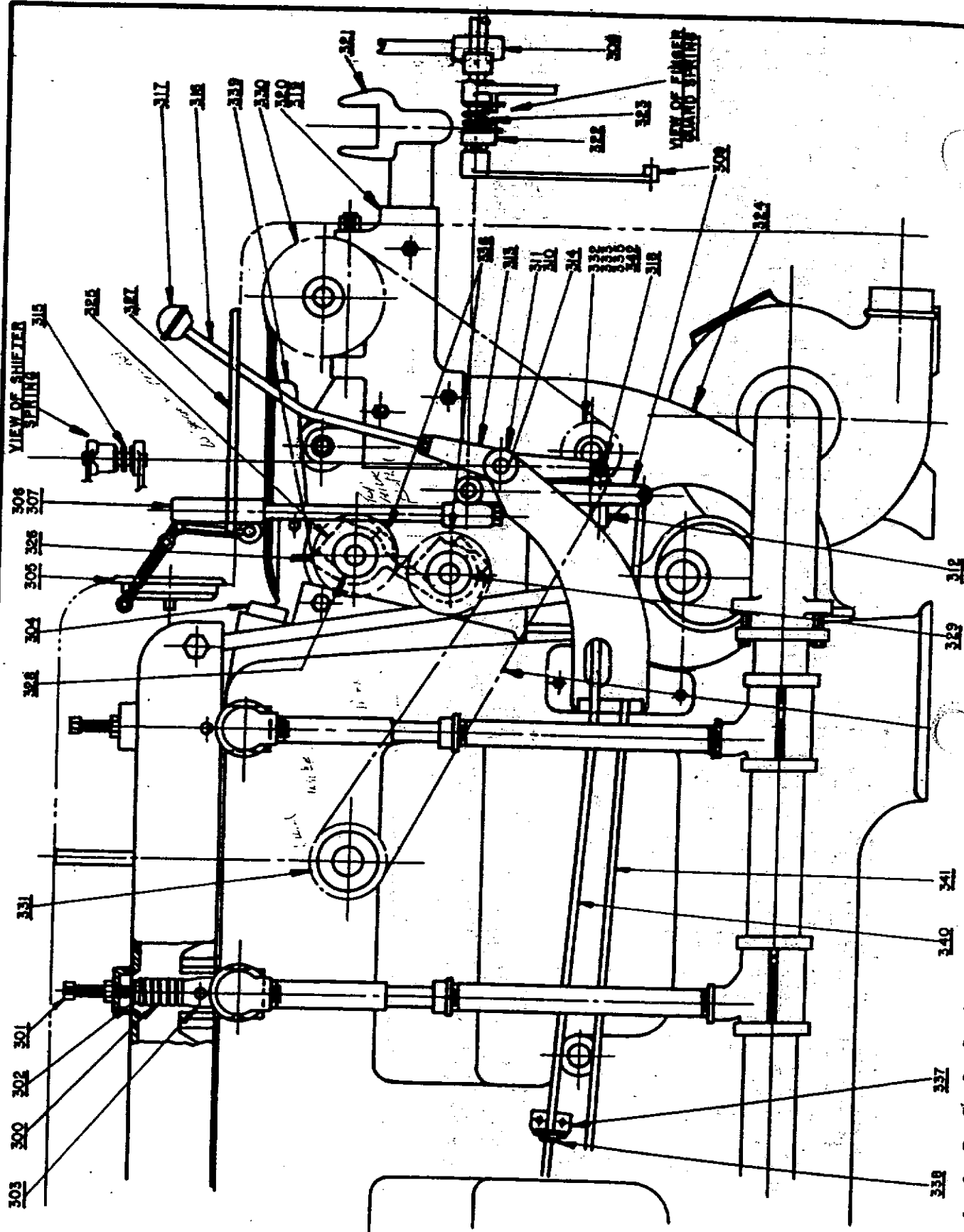

TYPICAL L.M. FRONT ENDSIDE ELEVATION  
 46 & 12 ROLL SYLON F.W. IRONER

THE AMERICAN LAUNDRY MACHINER CO.

SUPERSEDES

SUPERSEDED BY

5-16-47

114 RP	116 RP
118RP.6	110 RP

ITEM	NAME OF PART	PART NO.
300	PRESSURE SPRING	3118-657
301	SPECIAL SCREW	3116-6021
302	PRESSURE SPRING CAP	3116-121
303	ROLL BOX	110-160
304	L.H. BKT. FOR FEED BOARD	3118-1064
305	SPEEDOMETER HOLDER	110-164
306	L.H. FINGER GUARD SUPPORT ASSEM.	3116-0624
307	L.H. CASTING FOR FINGER GUARD	3116-1041
308	COUPLING FOR FINGER GUARD	3116-1043
309	LEVER FOR FINGER GUARD	118-21
310	CLUTCH LEVER ASSEM.	110-022
311	BRACKET	110-147
312	FORK	3118-195
313	LEVER	110-209
314	STUD	3118-6047
315	SPRING	31140-6083
316	LEVER EXTENSION	110-205
317	SHIFTER KNOB	15-25
318	PIN	361-674
319	ASSEM. UPPER L.H. RIBBON FEED BKT.	110-0125
320	L.H. BRACKET	110-1004
321	L.H. SHAKEOUT BAR BKT.	3116-1347
322	COLLAR FOR SPRING	3116-1387
323	SPRING FOR FINGER GUARD	3116-6484
324	L.H. LOWER RIBBON FEED BKT.	110-189
325	ASSEM. L.H. APRON DRIVE ROLL BKT.	118-012
326	L.H. BRACKET	118-103
327	CLUTCH LEVER SHIELD	110-186
328	UPPER BUSHING	3118-1088
329	LOWER BUSHING	3118-1089
330	FEED ROLL SPROCKET 30T. 3/4 P.	3118-425
331	DRIVE SPROCKET 19T. 3/4 P.	3118-447
332	IDLE SPROCKET 15T. 3/4 P.	3118-0419
333	BUSHING	COMM.
334	DRIVE CHAIN 3/4 P. 152 LINKS	118-614
335	IDLER STUD	3118-6118
336	APRON ROLL SPROCKET 21T. 3/4 P.	118-44
337	BRACKET FOR ROD BRG.	3118-199
338	BEARING	3118-1000
339	L.H. FEED BOARD BKT.	3116-1405
340	CLUTCH SHIFT ROD	3118-6044
341	KNOCKOUT ROD	118-619
342	15T <sup>3</sup> / <sub>4</sub> P SPROCKET <i>Bearing</i>	3118-438

TYPICAL L.H. FRONT END (PARTS LIST)  
 468812 ROLL SYLON FW IRONER

THE AMERICAN LAUNDRY MACHINERY CO

114RP	116RP
118RP6A	110RP



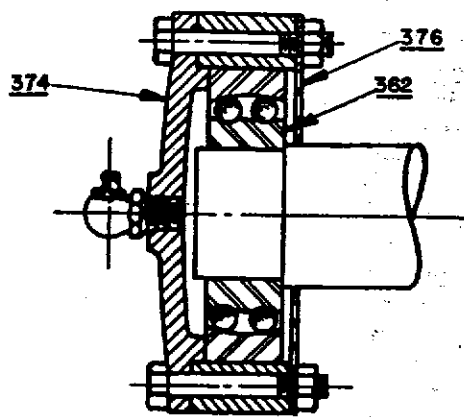

**SECTION OF APRON TENSION  
ROLL BEARINGS**

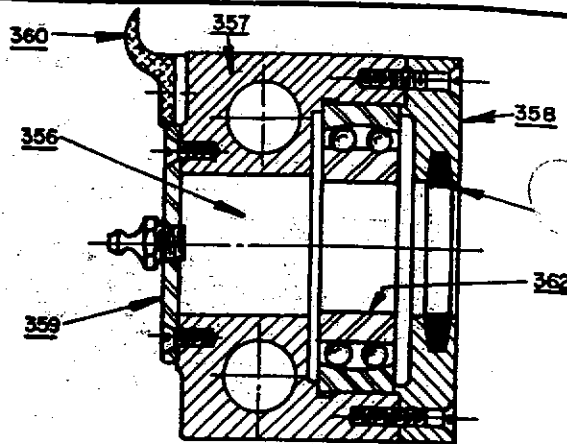

**SECTION OF SPIRAL  
ROLL BEARINGS**

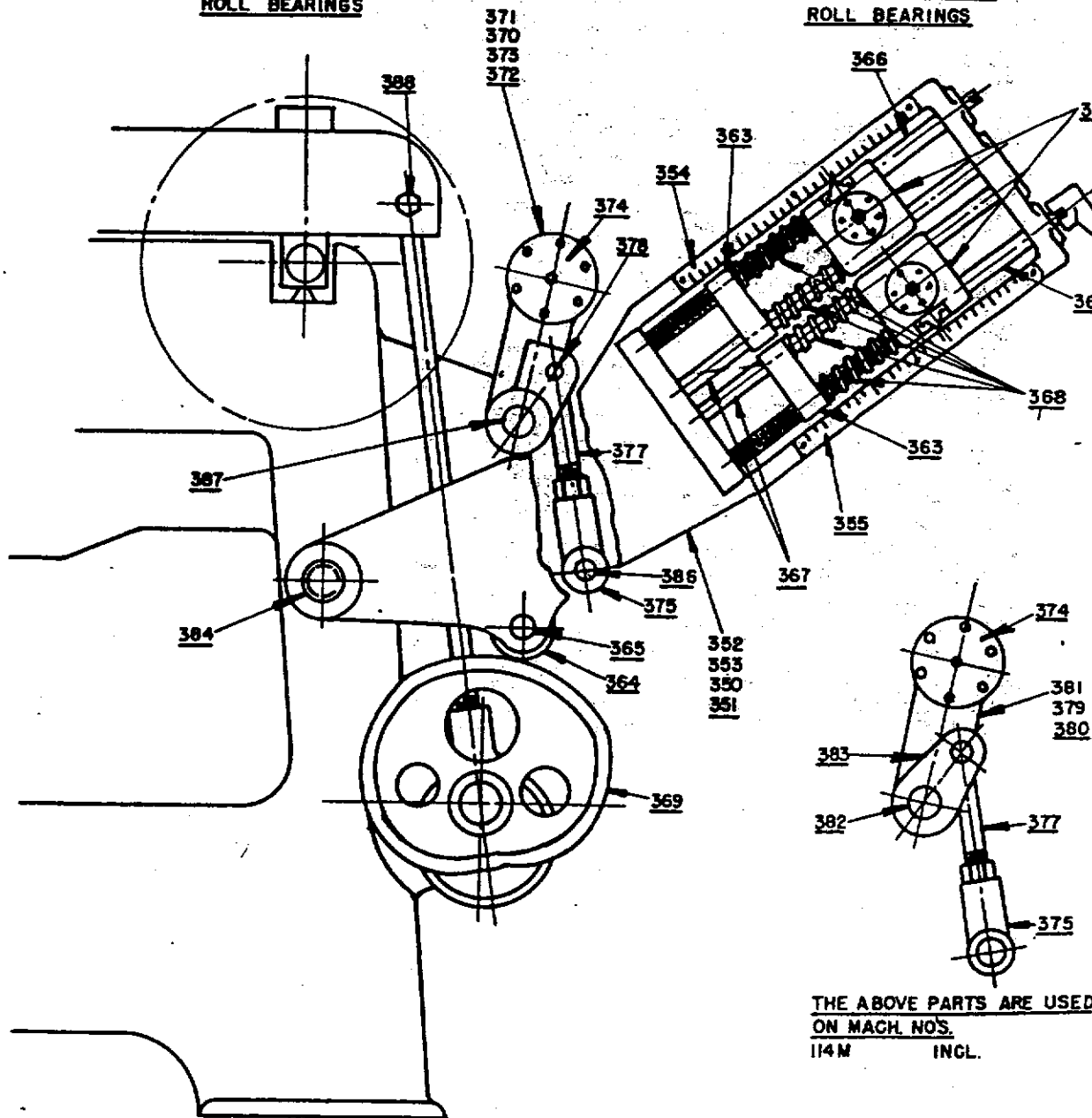

**TYPICAL DELIVERY END (R.H. SIDE ELEV.)  
4,6,8,812 ROLL SYLON F.W. IRONER**

**THE ABOVE PARTS ARE USED  
ON MACH. NOS.  
114M INCL.**

**SUPERSEDES**

**SUPERSEDED BY**

**THE AMERICAN LAUNDRY MACHINERY**

114RP	116RP
118RP.7	110 RP

ITEM	NAME OF PART	PART NO.
350	RH SPIRAL ROLL BRKT ASSEM.	3118-0116
351	LH SPIRAL ROLL BRKT ASSEM.	3118-0118
352	RH SPIRAL ROLL BRKT	3118-1018
353	LH SPIRAL ROLL BRKT	3118-1020
354	RH SCALE	3116-1196
355	LH SCALE	3116-1197
356	ASSEM. SPIRAL ROLL BRG.	3118-0117
357	BRG. HOUSING	3118-1015
358	RETAINER	3118-1016
359	COVER	3118-1017
360	POINTER	3116-1266
361	OIL RETAINER	3118-934
362	1307 SKF BEARING	COMM.
363	SPRING SUPPORT	3118-1019
364	CAM ROLLER	3116-6164
365	PIN	3116-6165
366	SCREW	3118-6075
367	GUIDE ROD	3118-6076
368	SPRING	3118-6077
369	CAM	3118-1068
370	RH APRON TENSION ROLL LEVER ASSEM.	118-014
371	LH APRON TENSION ROLL LEVER ASSEM.	118-015
372	RH LEVER	118-22
373	LH LEVER	118-23
374	COVER	3118-1021
375	CONN. ROD HEAD	3118-1098
376	COVER PLATE	3118-6078
377	CONN. ROD	3118-6239
378	PIN	3118-6240
379	RH APRON TENSION ROLL LEVER ASSEM.	3118-0144
380	LH APRON TENSION ROLL LEVER ASSEM.	3118-0145
381	BEARING LEVER	3118-29
382	PIVOT PIN	3118-6238
383	LEVER	3118-210
384	PIN FOR SPIRAL ROLL BRKT	3116-651
385	APRON TENSION HANDLE	3118-202
386	STUD FOR CONN. ROD	3118-6080
387	PIVOT STUD FOR APRON TENSION ROLL	118-626
388	BOLT IN PRESSURE BAR	3116-6137

TYPICAL DELIVERY END (RH SIDE ELEV) PARTS LIST  
4, 6, 8, 8 1/2 ROLL SYLON FWIRNER

THE AMERICAN LAUNDRY MACHINERY CO.

114RP	116RP
118RP 7A	110RP

ITEM	NAME OF PART	PART NO.	ITEM	NAME OF PART	PART NO.
397	APRON FRONT OLER BRG. ASSEM.	110-012	414	RIBBON SHAFT (100')	3116-6539
398	BRACKET	110-14	415	IDLE ROLL (100')	3140-0802
399	BUSHING	3116-1288	416	IDLE ROLL (110')	3140-0803
400	RIBBON FEED IDLE ROLL BRG.	110-0124	417	IDLE ROLL (120')	3140-0804
401	BRACKET	110-1002	418	RIBBON DRIVE ROLL (110')	3116-0883
402	BUSHING	3118-1034	419	RIBBON DRIVE ROLL (100')	3116-0898
403	STEEL FEED BOARD ASSEM. (120')	3116-06167	420	RIBBON DRIVE ROLL (120')	3116-0899
404	BRACKET	118-10	421	R.H. FINGER GUARD BRG.	3116-1162
405	ROD BRACKET	3116-1209	422	SHAKEOUT BAR (100')	3116-948
406	TRUSS ROD (120')	3116-6271	423	SHAKEOUT BAR (110')	3116-949
407	FINGER	3116-6538	424	SHAKEOUT BAR (120')	3116-950
408	RIBBON SHAFT (120')	3116-6541	425	CLOTH COVERING (100')	3116-965
409	STEEL FEED BOARD ASSEM. (110')	3116-06166	426	CLOTH COVERING (110')	3116-966
410	TRUSS ROD (110')	3116-6272	427	CLOTH COVERING (120')	3116-967
411	RIBBON SHAFT (110')	3116-6540	428	FINGER GUARD SHAFT (120')	110-6066
412	STEEL FEED BOARD ASSEM. (100')	3116-06165	429	FINGER GUARD SHAFT (110')	110-6066
413	TRUSS ROD (100')	3116-6273	430	FINGER GUARD SHAFT (80')	110-6067
			431	DOFFER ROLL ASSEM. (120')	3118-0870
			432	DOFFER ROLL ASSEM. (110')	3118-0877
			433	DOFFER ROLL ASSEM. (100')	3118-0887
			434	R.H. DOFFER ROLL BEARING	3118-1119
			435	L.H. DOFFER ROLL BEARING	3118-1120

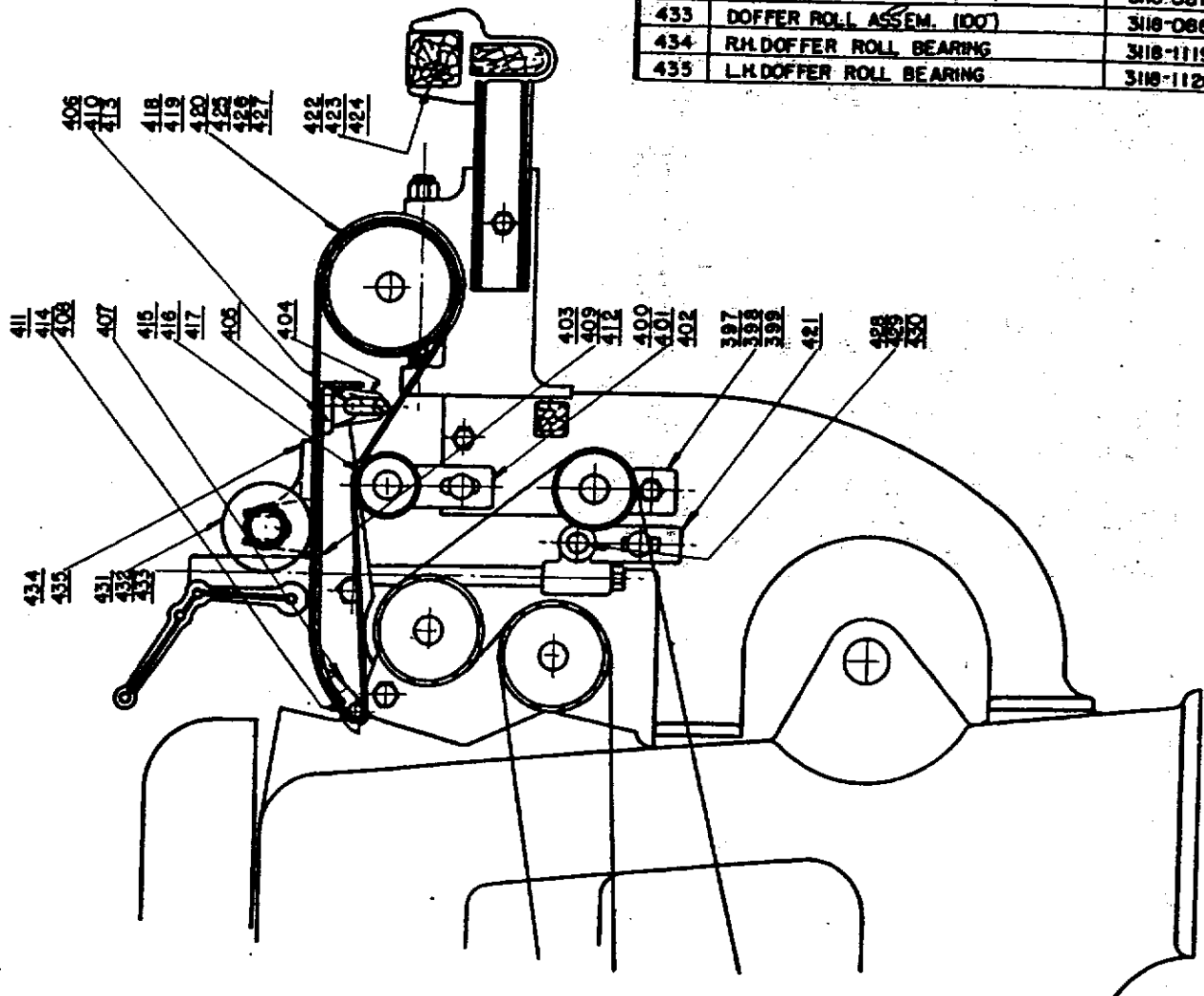

TYPICAL INSIDE SECTION OF FRONT END  
4.6, 8, & 12 ROLL SYLON FWIRONER

THE AMERICAN LAUNDRY MACHINERY CO.

SUPERSEDES

SUPERSEDED BY

7-14-47

114RP	116RP
118RP 8	110RP

ITEM	NAME OF PART	PART NO.
437	WASHER	316-636
438	CHAIN CONN. AT BELL CRANK	316-639
439	CHAIN CONN. AT ROLL	316-640
440	PIN	316-642
441	CHAIN	316-6178
442	NEEDLE FOR APRON GUIDE SPOOL	318-6181
443	APRON GUIDE SPOOL	316-8008

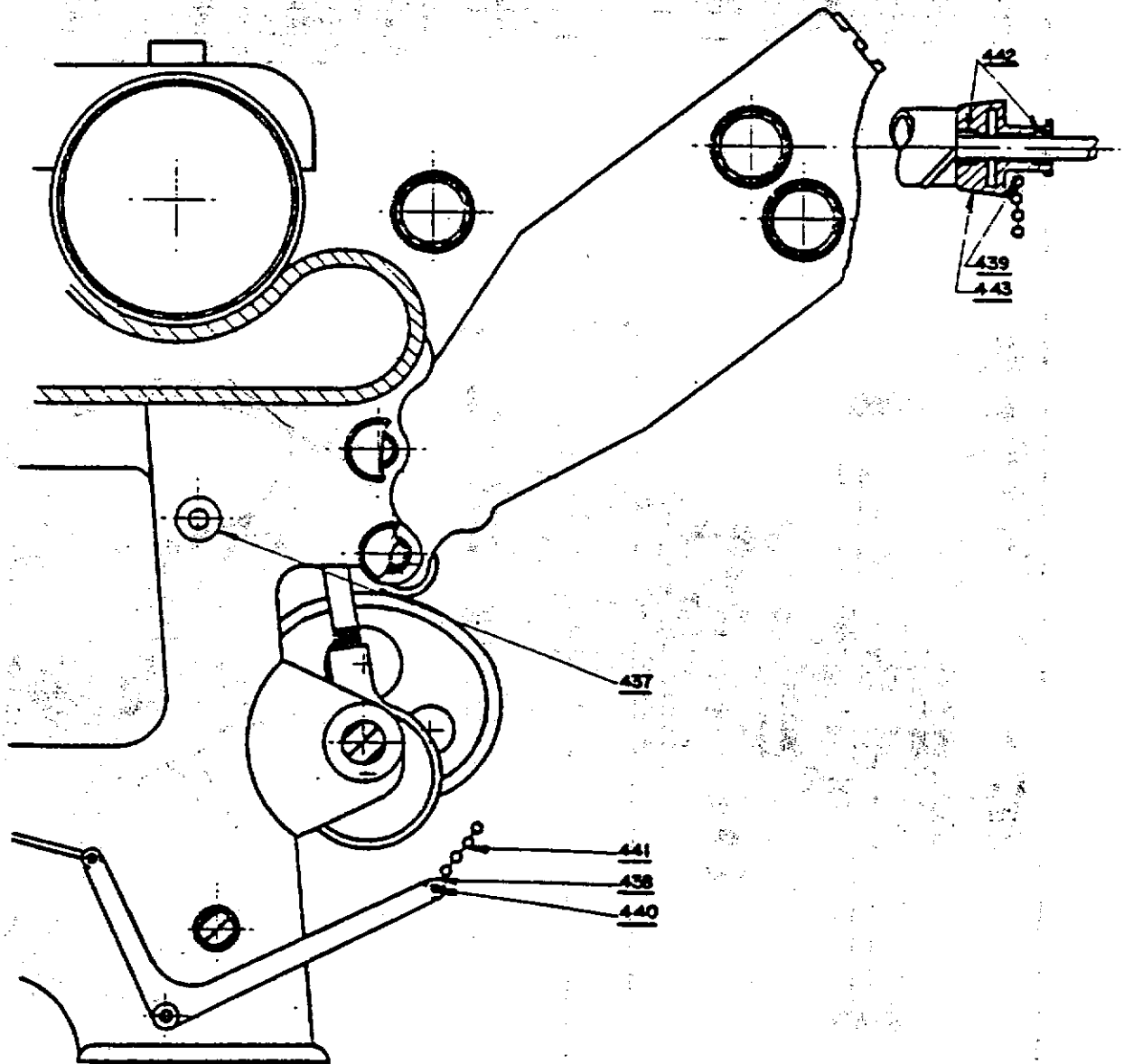

TYPICAL INSIDE SECTION OF DELIVERY END  
4, 6, 8, 9 1/2 ROLL SYLON FWIRONER

THE AMERICAN LAUNDRY MACHINERY CO.

114RP

116RP

SUPERSEDES

SUPERSEDED BY

7-15-47

116729

11673

ITEM	NAME OF PART	PART NO.	ITEM	NAME OF PART	PART NO.
453	ASSEM. PULLEY BRKT	118-010	489	FORK FOR ROD	3118-23
454	BALL BEARING FOR PULLEY BRKT	3118-0130	470	CONE LEVER	110-26
455	ASSEM. CONE BRKT	3118-0135	471	LEVER FOR CLUTCH	110-27
456	SHEAVE ASSEM. 30" PD.	3118-030	472	THROWOUT LEVER	3118-27
457	SHEAVE ASSEM. 26.75" PD.	3116-034	473	50T. SPEED IND. DRIVE GEAR	3116-1028
458	SHEAVE ASSEM. 30" PD.	3116-036	474	NOTCH COLLAR	110-617
459	CONE BRKT.	110-140	475	SHAFT	110-618
460	DISC HOUSING	3118-186	476	STUD FOR ROLLER	3118-6035
461	COVER	3118-189	477	STUD FOR FORK	3118-6040
462	PLATE FOR CONE BRKT.	3118-190	478	STUD FOR THROWOUT LEVER	3118-6041
463	SLIDING PIECE	3118-192	479	STUD FOR LEVER	3118-6055
464	UNIV. DRIVE HEAD WITHOUT CLAMP	31140-102	480	COLLAR	3118-6059
465	PULLEY BRKT.	3118-1056	481	ROLLER	3118-848
466	SUPPORT FOR DRIVE SHAFT	3118-1057	482	BOCKFORD FRICTION CLUTCH	COMM. 118-54
467	FORK FOR FRICTION CLUTCH	3118-1058	483	SPEED INDICATOR PINION BRKT.	110-158
468	BUSHING FOR SHEAVE	3116-1339	484	SPRING FOR THROWOUT LEVER	3118-6046
			485	THRUST COLLAR	118-104

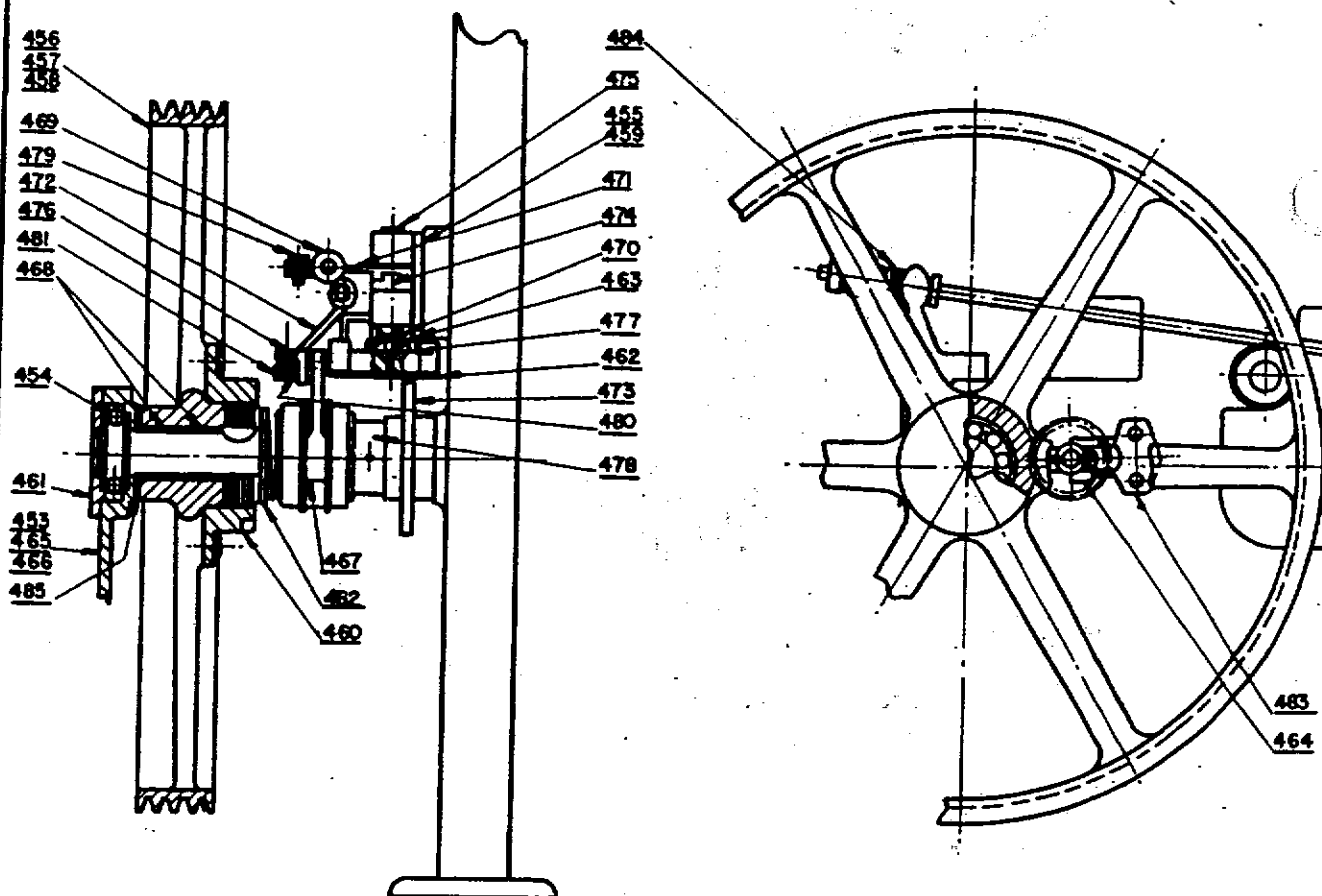

SECTION OF CLUTCH & DRIVE SHEAVE  
4 6 8 & 12 ROLL SYDOR F.W. IRONER

THE AMERICAN LAUNDRY MACHINERY CO.

114RP	116RP
11899 10	1100D

ITEM	NAME OF PART	PART NO.
493	BRKT FOR BEVEL GEAR SHAFT ASSEM.	110-0128
494	ROLL PRESSURE INDICATOR ASSEM.	110-0129
495	BUSHING FOR BRKT	102-113
496	CASE	110-182
497	SNAP RING	110-185
498	DIAL	110-1010
499	BEARING BRKT FOR BEVEL GEARS	110-1014
500	LOWER LEVER	110-218
501	RETAINING WASHER	3913-82
502	PIN FOR CONN. ROD	3121-645
503	NUT FOR CAM (P.R.R.)	110-648
504	SHAFT	110-6007
505	POINTER	110-6010
506	BEVEL GEAR SHAFT	110-6079
507	STUD FOR BEVEL PINION	110-6080
508	STL. BEVEL PINION 16T. 16P.	COMM.
509	STL. BEVEL PINION 32T. 16P.	COMM.
510	GLASS	110-96

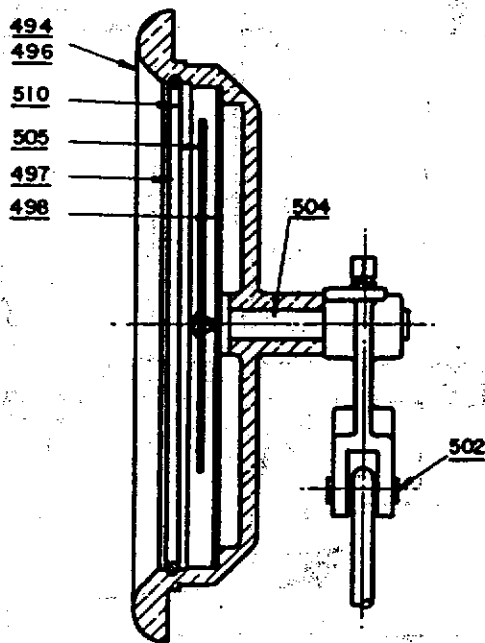

ROLL PRESSURE INDICATOR ASSEM.

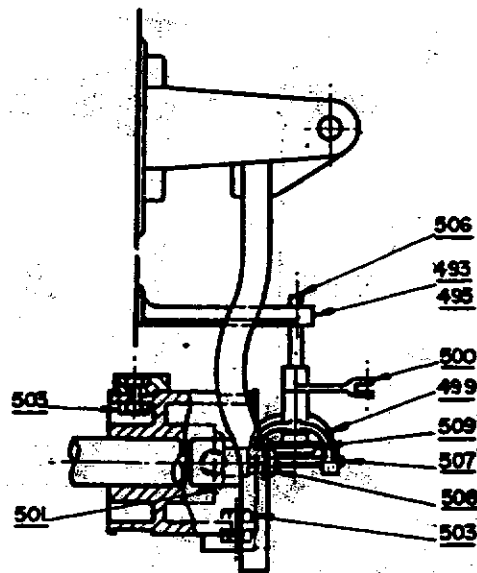

KNOCKOFF CAM HOLDER ASSEM.

ROLL PRESSURE INDICATOR MECHANISM  
4, 6, 8, & 12 ROLL SYLON FWJRONER

THE AMERICAN LAUNDRY MACHINERY CO.

114 RP	116 RP
110001	110002

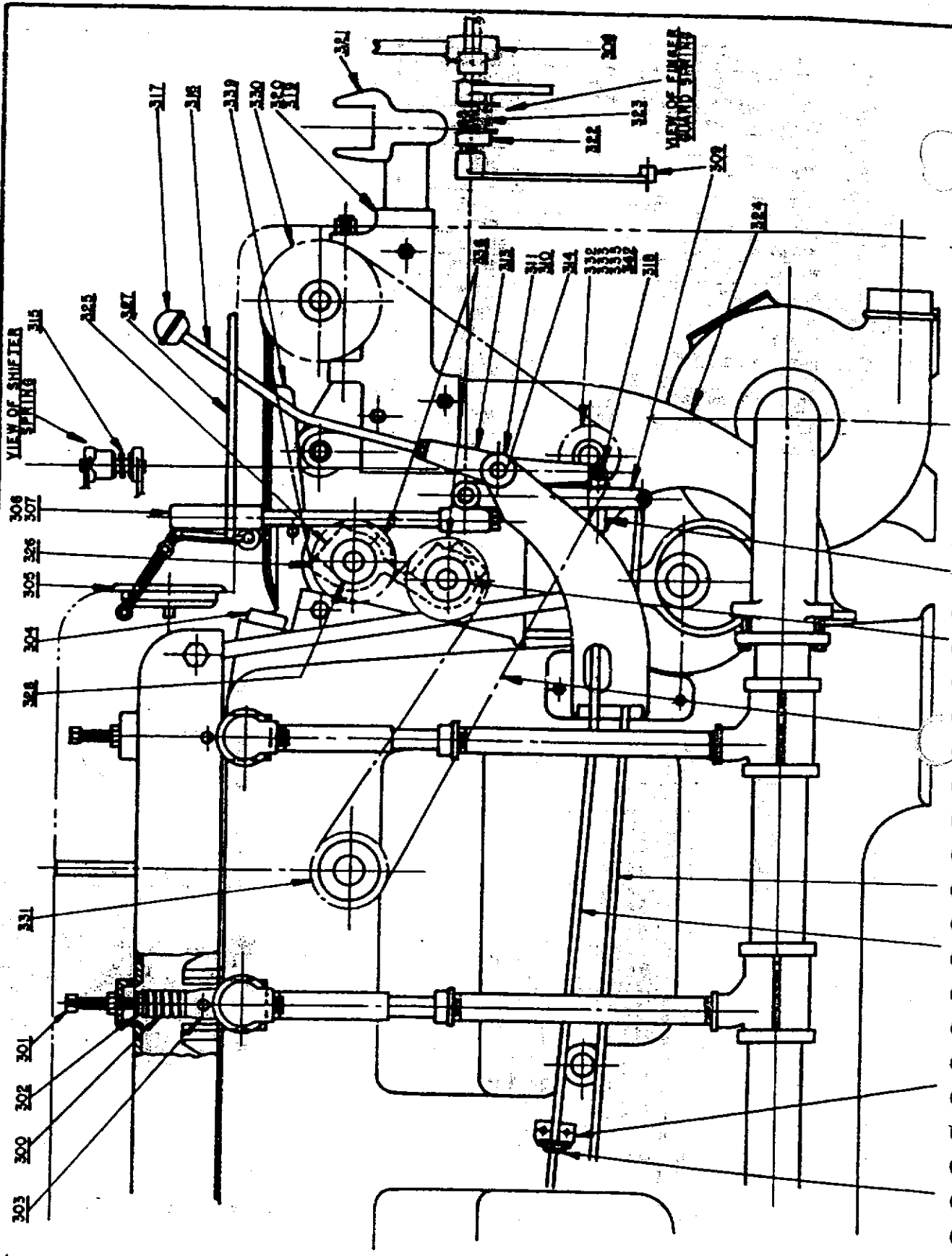

TYPICAL L.H. FRONT END (SIDE ELEVATION)  
 468B 12 ROLL SYLON F.W. IRONER

THE AMERICAN LAUNDRY MACHINER

114 RP	116 RP
118 RP, 6	119 RP

SUPP RSE D FS

SUPERSEDED BY

5-7-67

ITEM	NAME OF PART	PART NO.
225	CLUTCH SHIFTER SHAFT	110-6054
226	SHIFT LEVER PIN	110-6053
227	ASSEM. CLUTCH LEVER	110-0617
228	PIN	3116-8531
229	ROLLER	3116-8532
230	SHIFT LEVER	110-215
231	KNOCKOUT CAM HOLDER	110-1011
232	SUPPORT PLATE	110-1008
233	SUPPORT BRACKET	110-1001
234	CLUTCH SHIFTER	110-217
235	LOWER SHIFT LEVER	110-216
236	SHIFTER SPOOL	3116-1091
237	SHIFTER LEVER BRACKET	110-193
238	LEVER FOR PRESSURE INDICATOR	110-219
239	UPPER EYE ROD	110-8081
240	LOWER EYE ROD	110-8082
241	KNOCK OFF CAM	110-185
242	R.H. FINGER GUARD SUPPORT ASSEM.	3116-0823
243	SUPPORT	3116-1042
244	COUPLING	3116-1043
245	ROD	3116-8098
246	SHIFT LEVER EXTENSION	110-214
247	R.H. FEED BOARD BKT.	3116-1406
248	RIBBON	3116-947
249	ASSEM. UPPER R.H. RIBBON FEED BKT.	110-0126
250	BEARING ASSEM.	3116-01048
251	TAKE-UP SCREW	3116-6418
252	R.H. BRACKET	110-1003
253	R.H. SHAKEOUT BAR BKT.	3116-1348
254	HEX COLLAR	3116-6527
255	LOWER R.H. RIBBON FEED BKT.	110-190
256	BKT FOR BEVEL GEAR SHAFT	110-0128
257	BKT.	110-1013
258	BUSHING	102-113
259	RAISE RIG LEVER SHIELD	110-1012
260	ASSEM. FINGER GUARD 120	3116-06108
261	ASSEM. FINGER GUARD 110	3116-06107
262	ASSEM. FINGER GUARD 100	3116-06106
263	ASSEM. R.H. BRG. BRACKET	118-011
264	BUSHING	3118-1088
265	CAP	3116-1090
266	BRACKET	118-102
267	ASSEM. CHAIN IDLER LEVER	118-020
268	LEVER	118-20
269	BUSHING	3116-1329
270	SWIVEL PIN	118-815
271	SPROCKET AXLE	110-636
272	PIN FOR PENDULUM BOLT	31140-65
273	PIN FOR ROLL BOX	3116-852
274	SPRING	285-608
275	CONNECTING ROD	118-616
276	PIN	118-620
277	STUD	110-635
278	R.H. BKT. FOR STEEL FEED BOARD	3116-1269
280	SHIFTER KNOB	18-25

→ 128-900

TYPICAL R.H. FRONT END (PARTS LIST)  
 4, 6, 8, 12 ROLL SYLON F.W. IRONERS

THE AMERICAN LAUNDRY MACHINE CO.

112 AP

SUPERSEDED

SUPERSEDED BY



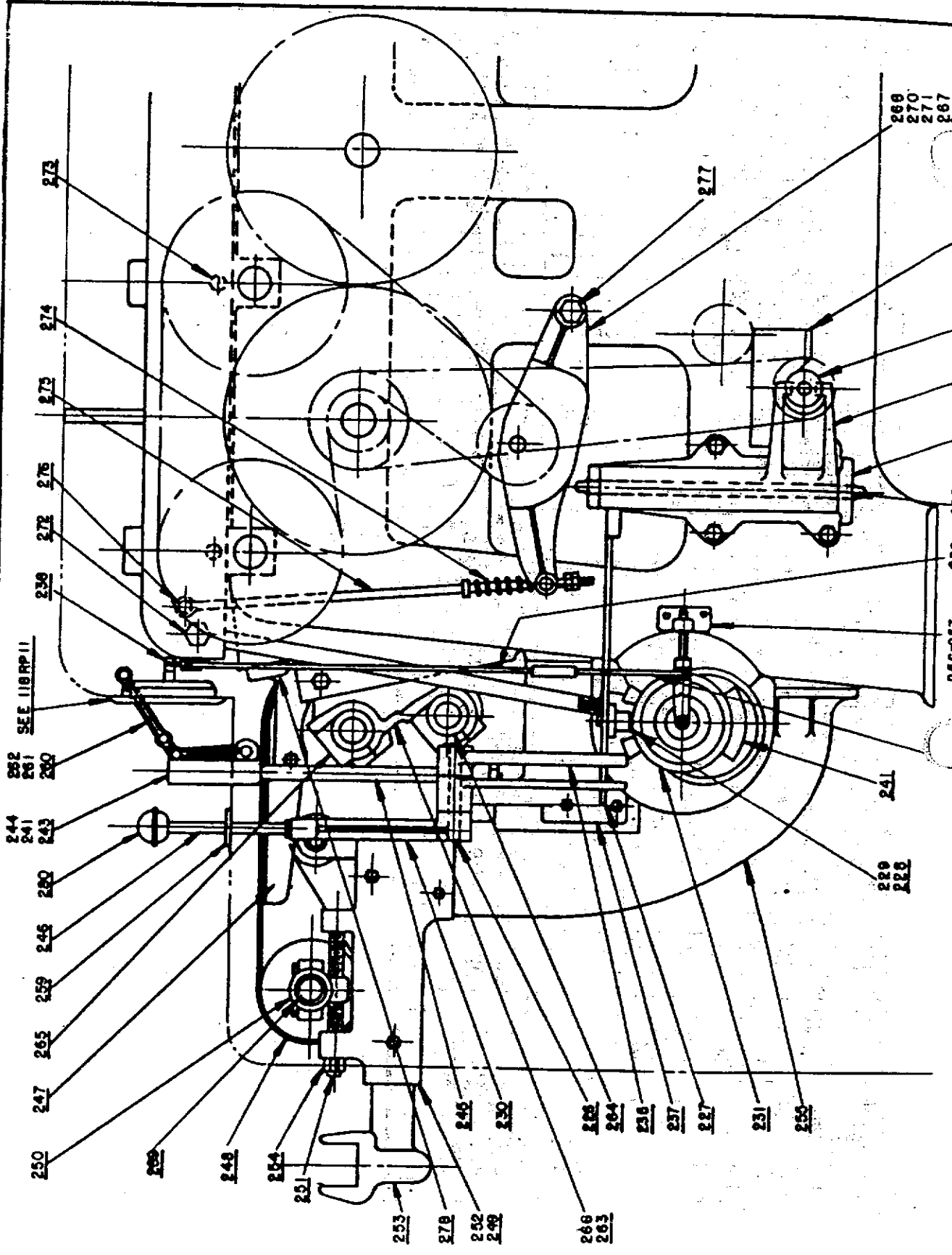

TYPICAL R.H. FRONT END(SIDE ELEVATION)  
 #6, 8, & 12 ROLL SYLON F.W. IRONERS

THE AMERICAN LAUNDRY MACHINERY CO.

114RP 116RP

SUPERSEDES

SUPERSEDED BY

5-16-47

118RP 119RP

ITEM	NAME OF PART	PART NO.
203	L.H. MANIFOLD	318-0723
204	WEIGHT	118-20
205	BELL CRANK (REAM)	318-257
206	BELL CRANK (WEIGHTED)	318-258
207	CONNECTING ROD	318-8081
208	CONNECTING ROD	318-8354
209	STUD	3140-8079
210	CHAIN & CONNECTOR	318-0843
211	CROSSOVER PIPE ASSEM. (605)	318-077
212	CROSSOVER PIPE ASSEM. (110')	318-078
213	CROSSOVER PIPE ASSEM. (20')	318-079

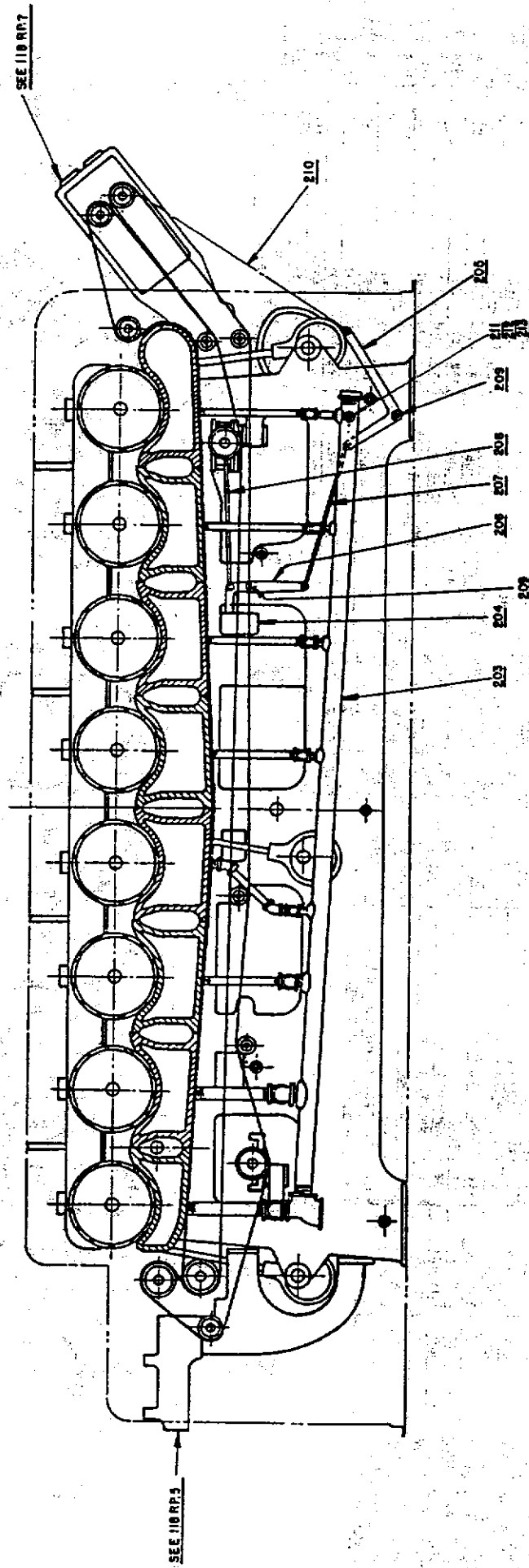

SECTIONAL ELEVATION OF INSIDE OF L.H. FRAME  
 1 ROLL SYLON F.W.L.

ITEM	NAME OF PART	PART NO.	ITEM	NAME OF PART	PART NO.	ITEM	NAME OF PART	PART NO.	ITEM	NAME OF PART	PART NO.	ITEM	NAME OF PART	PART NO.	ITEM	NAME OF PART	PART NO.
119	LOWER APRON ROLL	120	136	WORM SHAFT BRG. REAR	3118-0134	153	SPRING PADDED ROLL	100	170	SPIRAL TENSION ROLL	110	184	WORM SHAFT BRG. REAR	3118-0134	193	SPRING PADDED ROLL	100
120	UPPER APRON ROLL	120	137	CENTER WORM SHAFT BRG.	3118-029	154	STD. PADDED ROLL	100	154	STD. PADDED ROLL	100	171	SPIRAL TENSION ROLL	110	185	APRON GUIDE ROLL	100
121	SPIRAL TENSION ROLL	120	138	WORM OIL WELL	3118-1061	155	WORM SHAFT BRG. BRACKET		155	WORM SHAFT BRG. BRACKET	3118-1062	172	APRON IDLER ROLL	110	186	2ND CHEST	100
122	SPIRAL ROLL	120	139	WORM OIL WELL	3118-204	156	BUSHING		156	BUSHING	3118-027	173	APRON IDLER ROLL	110	187	3RD CHEST	100
123	APRON GUIDE ROLL	120	140	BELL CRANK REAR	3118-238	157	SLINGER		157	SLINGER	3118-027	174	APRON IDLER ROLL	110	188	4TH CHEST	100
124	FRONT APRON IDLER ROLL	120	141	BELL CRANK (WEIGHTED)	3118-238	158	PIV		158	PIV	3118-027	175	APRON IDLER ROLL	110	189	5TH CHEST	100
125	APRON IDLER ROLL	120	142	RIGHT WORM	110-40	159	CHAIN & CONNECTOR		159	CHAIN & CONNECTOR	3118-043	176	2ND CHEST	100	190	6TH CHEST	100
126	1ST STEAM CHEST	120	143	LEFT WORM	110-41	160	FRONT APRON IDLER ROLL	110	160	FRONT APRON IDLER ROLL	110	176	2ND CHEST	100	191	7TH CHEST	100
127	2ND STEAM CHEST	120	144	RIGHT WORM GEAR	110-43	161	FRONT APRON IDLER ROLL	100	161	FRONT APRON IDLER ROLL	100	177	2ND CHEST	100	192	8TH CHEST	100
128	3RD STEAM CHEST	120	145	LEFT WORM GEAR	110-42	162	LOWER APRON DRIVE ROLL	110	162	LOWER APRON DRIVE ROLL	110	178	3RD CHEST	100	193	9TH CHEST	100
129	4TH STEAM CHEST	120	146	WORM GEAR COVER	110-501	163	LOWER APRON DRIVE ROLL	100	163	LOWER APRON DRIVE ROLL	100	179	3RD CHEST	100	194	UPPER APRON	110
130	5TH STEAM CHEST	120	147	STUD	3118-936	164	UPPER APRON DRIVE ROLL	110	164	UPPER APRON DRIVE ROLL	110	180	4TH CHEST	100	195	LOWER APRON	110
131	6TH STEAM CHEST	120	148	CONNECTING ROD	3118-818	165	UPPER APRON DRIVE ROLL	100	165	UPPER APRON DRIVE ROLL	100	181	4TH CHEST	100	196	UPPER APRON	110
132	7TH STEAM CHEST	120	149	CONNECTING ROD	3118-817	166	SPIRAL ROLL	110	166	SPIRAL ROLL	110	182	6TH CHEST	100	197	LOWER APRON	110
133	8TH STEAM CHEST	120	150	WORM SHAFT	3118-818	167	SPIRAL ROLL	100	167	SPIRAL ROLL	100	183	6TH CHEST	100	198	LOWER APRON	110
134	UPPER APRON	120	151	STUD	3118-8163	168	APRON GUIDE ROLL	110	168	APRON GUIDE ROLL	110	184	6TH CHEST	100	199	LOWER APRON	110
135	LOWER APRON	120	152	R.H. STEAM MANIFOLD (INLET)	3118-945	169	APRON GUIDE ROLL	100	169	APRON GUIDE ROLL	100	185	6TH CHEST	100	200	LOWER APRON	110
			153	HIGH SAFETY VALVE (SPECIAL)	COMM	170	STD. PADDED ROLL	100	170	STD. PADDED ROLL	100	186	7TH CHEST	100			
			154			171	STD. PADDED ROLL	100	171	STD. PADDED ROLL	100	187	7TH CHEST	100			
			155			172	SPRING PADDED ROLL	110	172	SPRING PADDED ROLL	110	188	8TH CHEST	100			
						173	SPRING PADDED ROLL	100	173	SPRING PADDED ROLL	100	189	8TH CHEST	100			
						174			174			190	UPPER APRON	110			
						175			175			191	UPPER APRON	110			
						176			176			192	LOWER APRON	110			
						177			177			193	LOWER APRON	110			
						178			178			194	LOWER APRON	110			
						179			179			195	LOWER APRON	110			
						180			180			196	LOWER APRON	110			
						181			181			197	LOWER APRON	110			
						182			182			198	LOWER APRON	110			
						183			183			199	LOWER APRON	110			
						184			184			200	LOWER APRON	110			
						185			185								
						186			186								
						187			187								
						188			188								
						189			189								
						190			190								
						191			191								
						192			192								
						193			193								
						194			194								
						195			195								
						196			196								
						197			197								
						198			198								
						199			199								
						200			200								

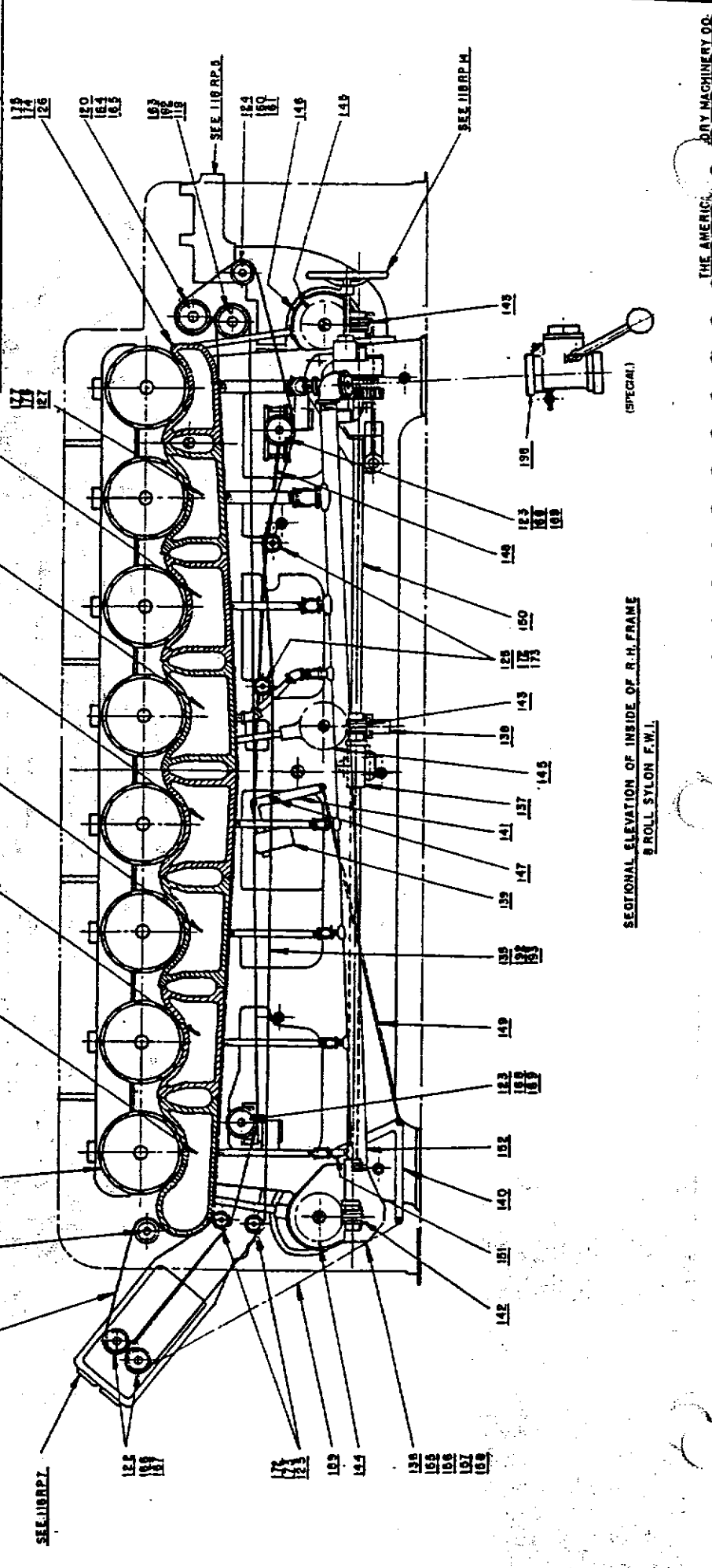

SECTIONAL ELEVATION OF INSIDE OF R.H. FRAME  
9 ROLL SYLON F.W.L.

1-11-47  
L.H. FRONT END GUARD RIB FEED A.G.  
3118-0657

ITEM NO.	DESCRIPTION	ITEM NO.	DESCRIPTION	ITEM NO.	DESCRIPTION
84	L.H. FRAME	97	MANIFOLD SUPPORT SKT.	3118-1002	
85	BUSHING	98	MANIFOLD SUPPORT	3118-6038	
86	BUSHING	99	INTAKE ELBOW	110-72	
87	EXHAUST MANIFOLD ASSEM.	100	L.H. MAIN GUARD	118-089	
88	LOWER PIPE	101	L.H. FRONT END GUARD (RIBBON FEED)	118-0508	
89	MANIFOLD	102	L.H. FRONT END GUARD (CONVEYOR)	3118-0867	
90	LOCKING RING	103	L.H. FRONT END GUARD (SPREADER)	110-0524	
91	TEE	104	L.H. PRESSURE BAR	3118-240	
92	UPPER PIPE	105	FRONT BASE ANGLE - MAIN GUARD	3118-0863	
93	SLIP JOINT	106	FR. BASE ANGLE (RIBBON FEED)	3118-0864	
94	TEE	107	FR. END BASE ANGLE (CONVEYOR)	3118-0867	
95	PACKING	108	FR. END BASE ANGLE (SPREADER)	110-0611	
96	PACKING	109	REAR BASE ANGLE - MAIN GUARD	3118-0583	

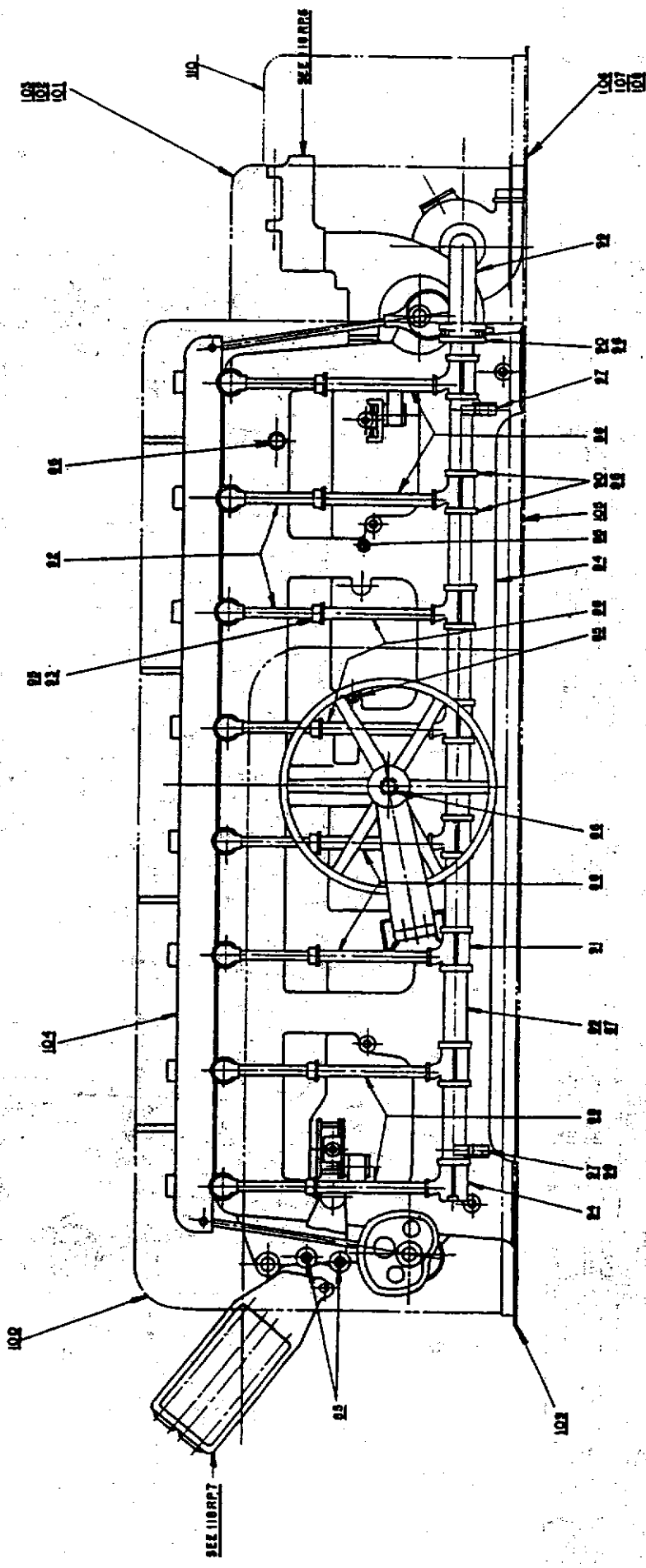

L.H. OUTSIDE ELEVATION  
8 ROLL RYLOX FW.1

THE AMERICAN LAUNDRY MACHINERY CO.  
5-16-47

SUPERSEDED BY

118RP.2

PART NO.	ITEM	NAME OF PART	PART NO.	ITEM	NAME OF PART	PART NO.
1	R.H. FRAME		3118-655	32	ECCENTRIC SHAFT (REAR)	118-58
2	BUSHING		3118-656	33	IDLER SPROCKET ASSEM.	118-040
3	BUSHING		3118-430	54	SPROCKET 15T-1P.	118-41
4	BUSHING		118-58	55	BUSHING	COMM.
5	STUD		3118-1099	56	R.H. GUARD ASSEM.	118-059
6	STUD		3118-6176	57	R.H. FRONT END GUARD/DRIBBON FEED	3118-0558
7	STUD		3118-6176	58	R.H. FRONT END GUARD/CONVEYOR	3118-0559
8	GEAR & SPROCKET ASSEM.		118-601	59	R.H. FRONT END GUARD (SPREADER)	3118-0682
9	ROT-5P GEAR		118-602	60	BASE ANGLE - MAIN GUARD	3118-0681
10	2.4T-3/4 P. SPROCKET		110-849	61	BASE ANGLE - RIBBON FEED	110-0610
11	12T-1P SPROCKET		118-93	62	BASE ANGLE - CONVEYOR	110-658
12	IDLER GEAR ASSEM.		3118-64	63	BASE ANGLE - SPREADER	110-658
13	ROT-1P GEAR		110-8123	64	RAISE RIG CHAIN - 92 LINKS-3/4 P.	110-658
14	BUSHING		118-80			
15	GEAR & SPROCKET ASSEM.		118-81			
16	ROT-4P GEAR		3118-865			
17	12T-1P SPROCKET		118-85			
18	BUSHING		110-1340			
19	HERRINGBONE GEAR ASSEM.		118-042			
20	HERRINGBONE GEAR 216T-9P.		118-43			
21	SHAFT 120"		3118-6164			
22	SHAFT 110"		118-606			
23	SHAFT 100"		118-606			
24	ROLL SPROCKET		118-43			
25	ROLL CHAIN 1 P. 92 LINKS		118-612			
26	RAISE RIG & SPROCKET 12T-3/4P.		110-122			
27	IDLER ASSEM.		3118-0418			
28	SPROCKET 15T-3/4P.		3118-426			
29	BUSHING		COMM.			
30	ECCENTRIC		110-130			
31	ECCENTRIC STRAP		110-133			
32	ECCENTRIC ROD		3118-9347			
33	SUPPORT STUD		110-637			
34	TIE ROD		3118-654			

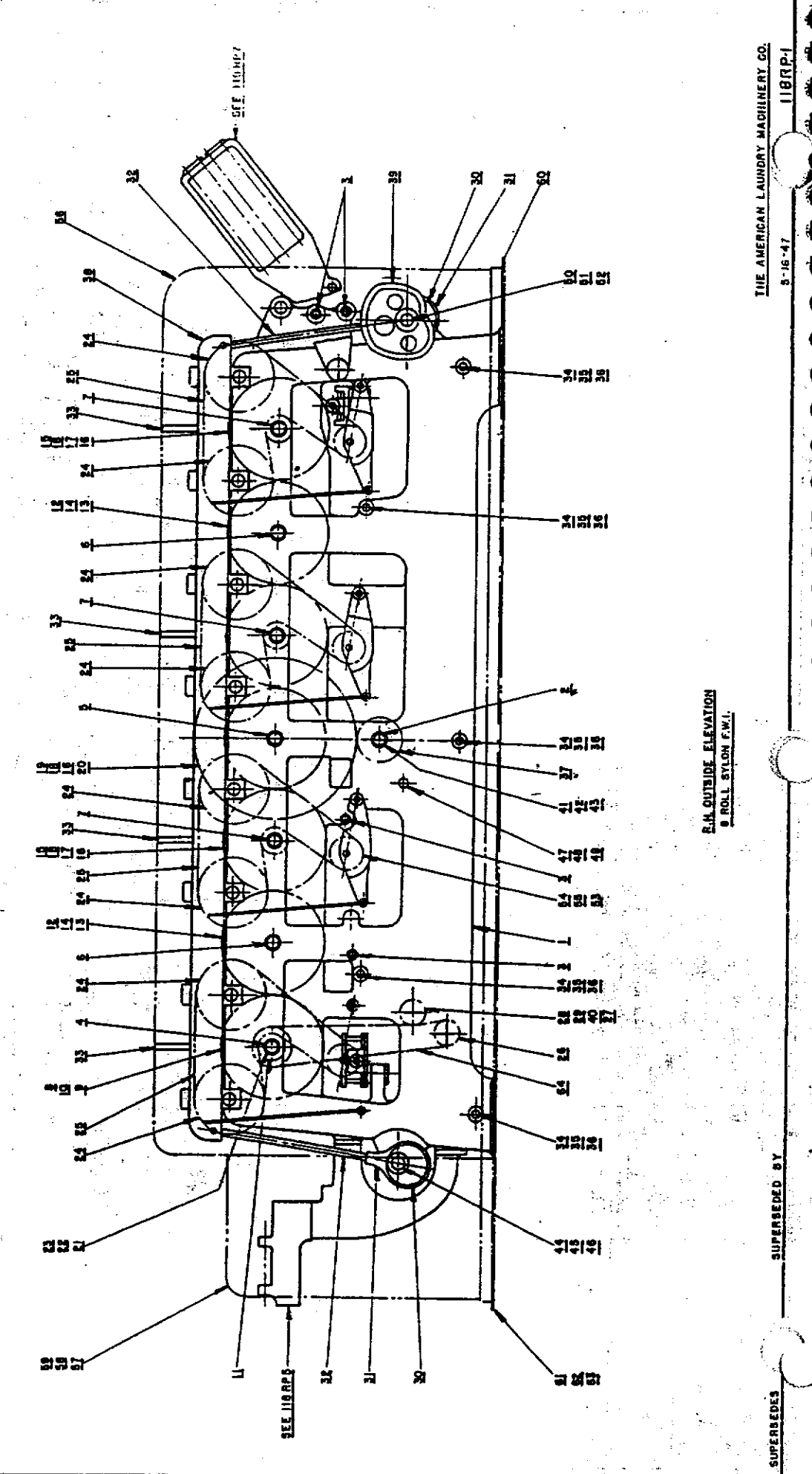

R.H. OUTSIDE ELEVATION  
 8 ROLL SYLON F.W.I.

ITEM	NAME OF PART	PART NO.	ITEM	NAME OF PART NO.	PART NO.
520	EXHAUST FAN HOUSING ASSEM.	3116-01053	535	SWING JOINT BODY	3116-730
521	VACUUM MANIFOLD	110-0703	536	SWING JOINT COVER	3116-731
522	ASSEM. SWING JOINT	3116-0726	537	PACKING FOR SWING JOINT	3116-982
523	SUPPORT BRKT.	3116-1363	538	PACKING FOR SLIP JOINT	31140-941
524	MOTOR BRKT.	3116-1364	539	GARLOCK PACKING NO.17	COMM.
525	WRENCH FOR SWING JOINT	3116-259	540	R.H. EXHAUST FAN HOUSING ASSEM.	3116-01054
526	IMPELLER	3116-319	541	R.H. HOUSING	3116-5060
527	APRON ROLL SPROCKET 21T. 4P.	118-44	542	COVER	3116-6390
528	EXHAUSTER HOUSING	3116-5034	543	GASKET	3116-983
529	ANGLE IRON HOLDING OIL PIPES	3116-6283			
530	SWING JOINT LOCK	3116-6422			
531	SLIP JOINT LOWER PIPE	110-73			
532	SPLIT COLLAR	31140-73			
533	SLIP JOINT UPPER PIPE	31140-703			
534	SLIP JOINT LOCKING NUT	31140-705			

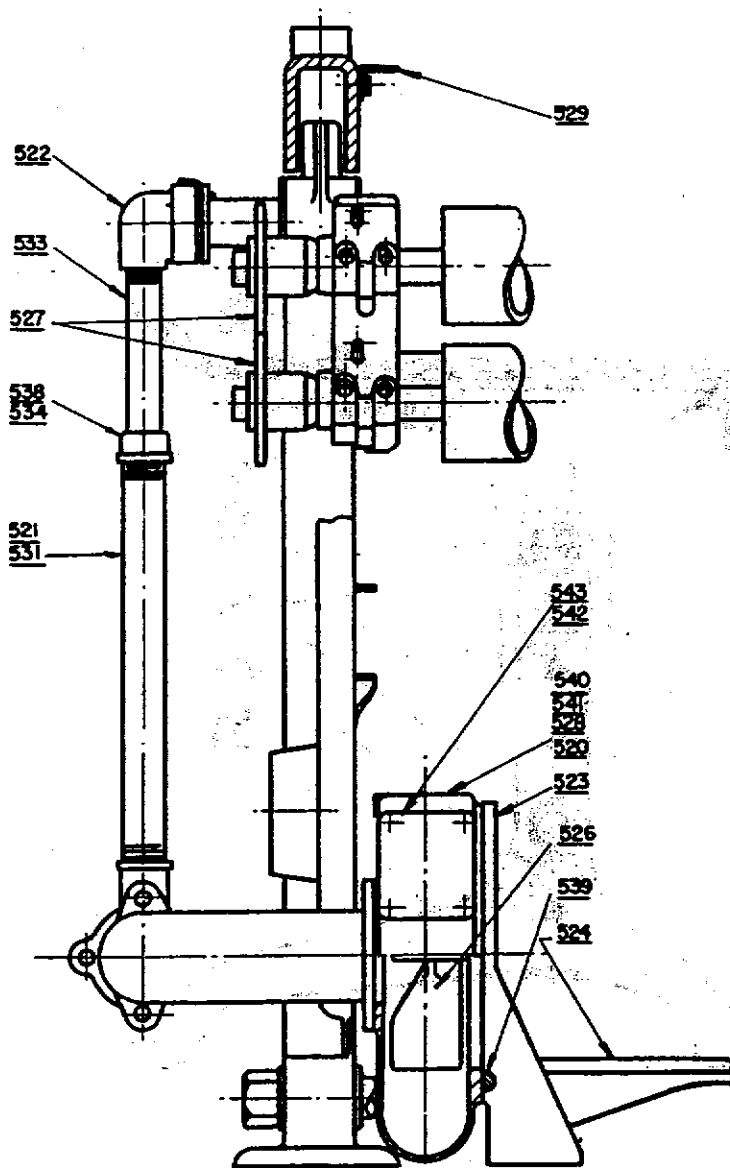

END VIEW SHOWING VACUUM EXHAUSTER SYSTEM

END VIEW OF VACUUM EXHAUSTER 4.6.8 & 12 ROLL SYLON FW IRONER

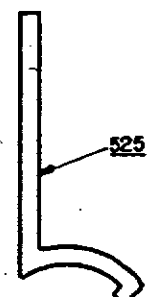

SWING JOINT WRENCH

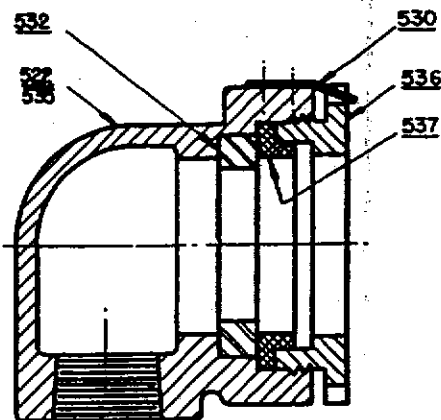

SECTION OF SWING JOINT FOR VACUUM EXHAUST

THE AMERICAN LAUNDRY MACHINERY CO

SUPERSEDES

SUPERSEDED BY

7-16-47

114RP	116RP
118RP 12	110RP

ITEM	NAME OF PART	PART NO.
550	ADJUSTABLE TABLE LEG-ASSEM.	110-0527
551	DELIVERY TABLE (110')	116-090
552	DELIVERY TABLE (100')	116-091
553	DELIVERY TABLE (120')	3118-0916
554	BRACKET	3116-1190
555	CAST IRON WASHER	3116-1231
556	FOOT FOR ADJ. LEG	116-513
557	TOP FOR ADJ. LEG	116-514
558	HINGE PIN	3116-6302
559	TIE PIPE (120')	3118-707

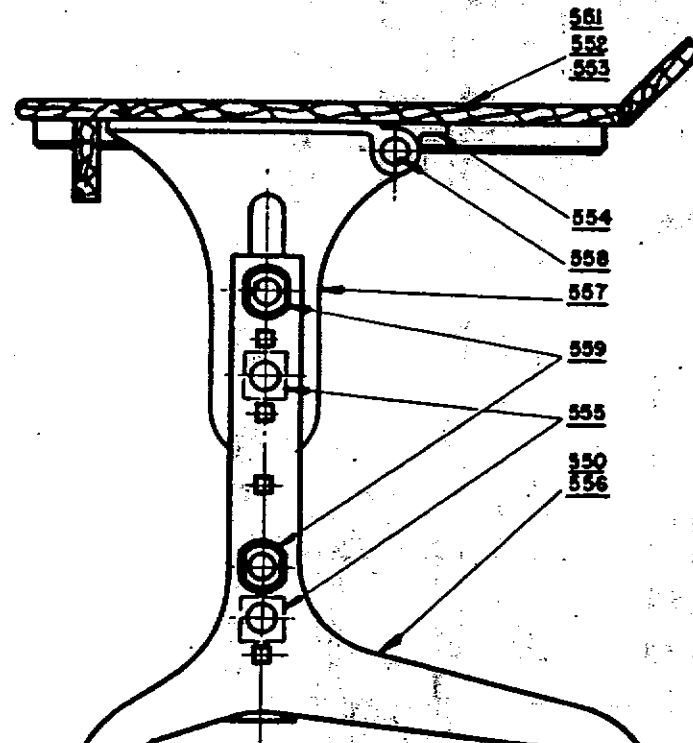

ITEM	NAME OF PART	PART NO.
569	RAISING RIG ASSEM.	110-0132
570	SPUR GEAR ASSEM. INTER. SHAFT	110-0405
571	MAIN BRACKET	110-1007
573	THRUST BRG. FOR PINION	3116-1069
574	SHIFTER SPOOL	3116-1091
575	HAND WHEEL	3116-303
576	34T 5P SPUR GEAR	110-48
577	BEVEL GEAR	110-408
578	14T 5P SPUR GEAR (MEEH.)	3116-428
579	32T 5P SPUR GEAR (MEEH.)	3116-429
580	BEVEL PINION	110-431
581	14T 5P SPUR GEAR (STL.)	110-434
582	14T 5P SPUR GEAR (STL.)	110-435
583	20T 5P SPUR GEAR (STL.)	110-436
584	BEVEL GEAR COVER	3116-680
585	CLUTCH SHAFT	110-620
586	CLUTCH KEY	110-644
587	HAND WHEEL SHAFT	110-6072
588	GEAR SHAFT	110-6073
589	SPRING FOR SPACER	110-6075
590	SHIFTER ROD	110-6078
591	SPACER FOR CLUTCH GEAR	3116-6159
592	PIN	3116-6182
593	GUARD FOR RAISE RIG	118-0511

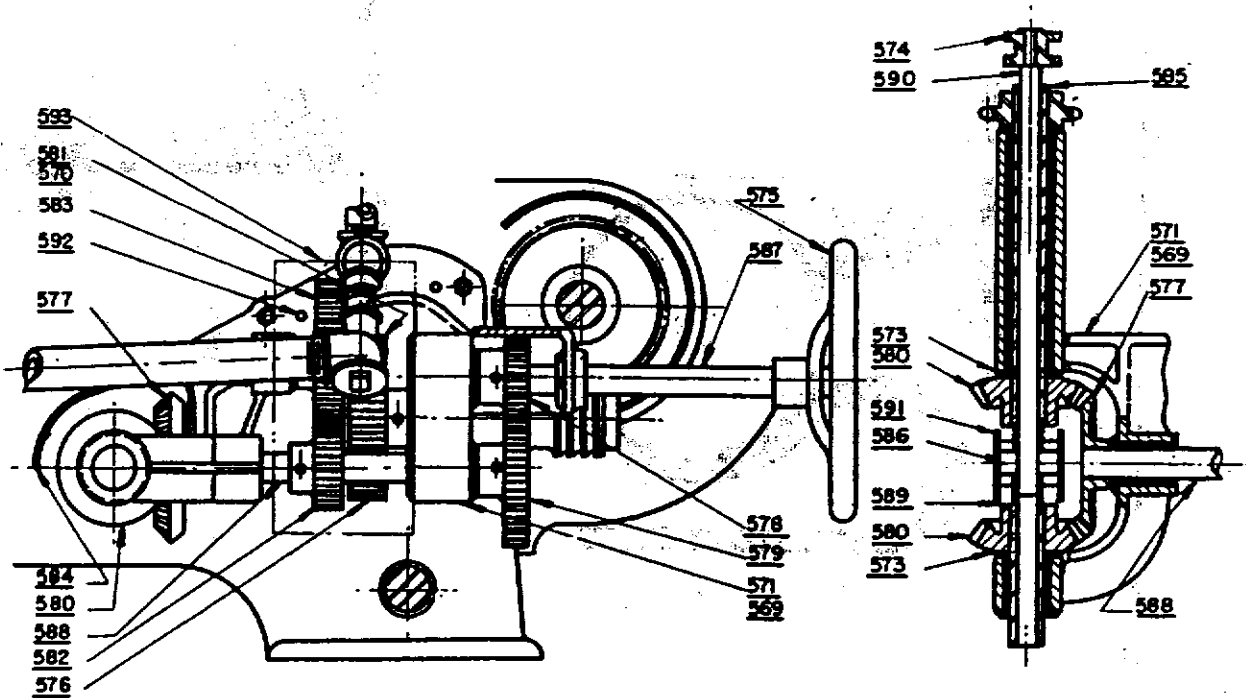

RAISING RIG ASSEMBLY  
6, 8, & 12 ROLL SYLON F.W. IRONERS

THE AMERICAN LAUNDRY MACHINERY CO.

SUPERSEDES

SUPERSEDED BY

T-22-47

116RP

118 RP 14



ITEM	NAME OF PART	PART NO
602	ASSEM. SPOOL ARM	386-01088
603	ASSEM. SPOOL ROD (120")	316-06125
604	ASSEM. SPOOL ROD (110")	316-06126
605	ASSEM. SPOOL ROD (100")	316-06127
606	REAR RIBBON SPOOL BRKT	318-1084
607	SPOOL ARM	316-1356
608	R.H. BRKT FOR SPOOL	316-1358
609	L.H. BRKT FOR SPOOL	316-1359
610	SPOOL ARM HOLDER	316-1431
611	PIN FOR SPRING	1802-605
612	SPRING	1802-606
613	STUD	316-6419
614	SPOOL ROD (120")	316-6421
615	SPOOL ROD (110")	316-6423
616	SPOOL ROD (100")	316-6425
617	SPOOL ARM SUPPORT (100)	316-6584
618	SPOOL ARM SUPPORT (110)	316-6585
619	SPOOL ARM SUPPORT (120)	316-6586
620	SPOOL STOP	316-920
621	WOOD SPOOL	316-989
622	TAPE	316-986

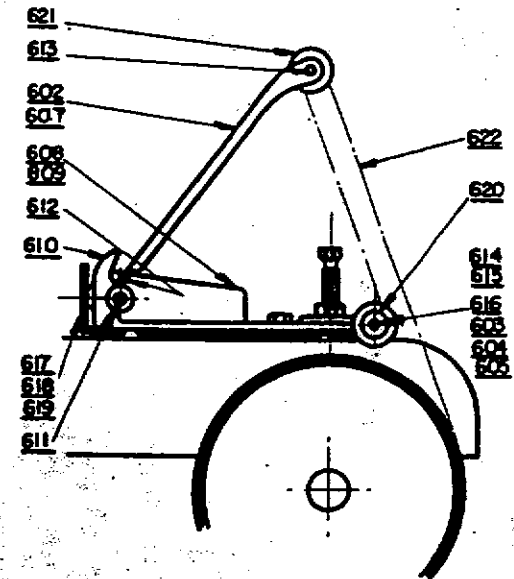
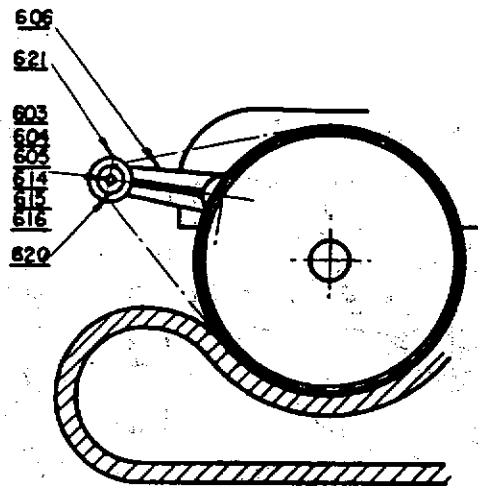

ITEM	NAME OF PART	PART NO.
631	GUIDE BLOCK FOR CHESTS	3116-277
632	CRANK FOR HAND DRIVE	3116-242
633	PIN FOR GUIDE BLOCK	30-609
634	NO.7 EYEBOLT FOR GUARDS	3619-6035

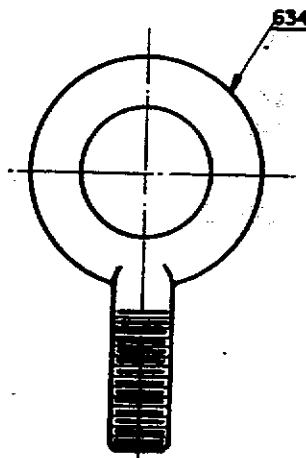

EYEBOLT FOR GUARDS

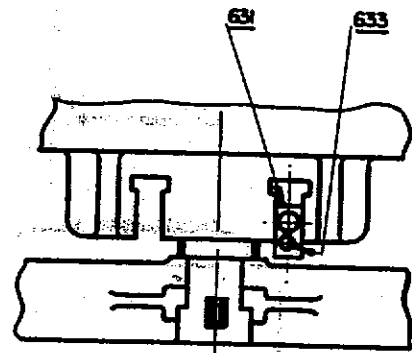

METHOD OF MOUNTING CHESTS

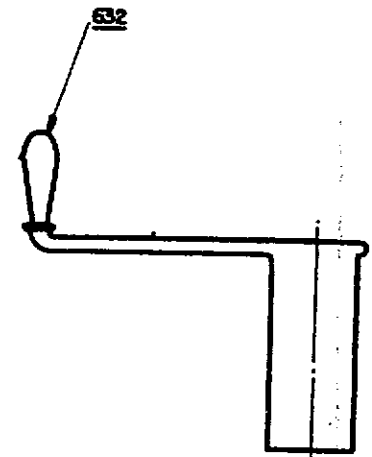

HAND CRANK

ITEM	NAME OF PART	PART NO.
685	ASSEM. THERMOMETER WELL	316-0707
686	THERMOMETER SUPPORT	316-6293
687	THERMOMETER WELL	316-705

